

GÜÇLÜ BİR GELECEK İÇİN STRONGER FOR THE FUTURE



www.activent.com.tr



ACTIVENT®

ÜRÜN KATALOĞU
PRODUCT CATALOGUE



RADYAL FANLAR
RADIAL FANS

RADYAL FAN YÖNLERİ RADIAL FAN DIRECTIONS

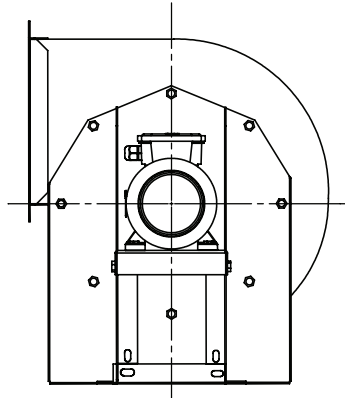

L180

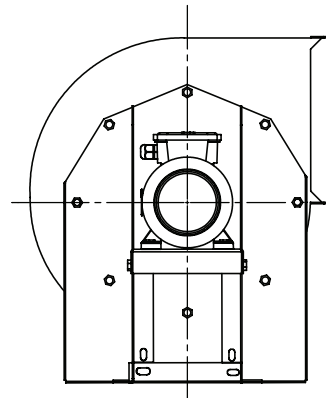

R180

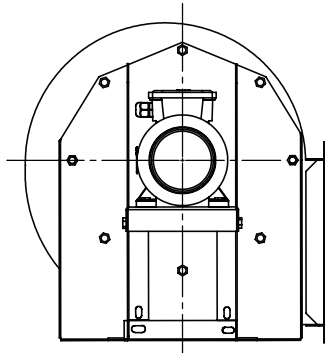

L270

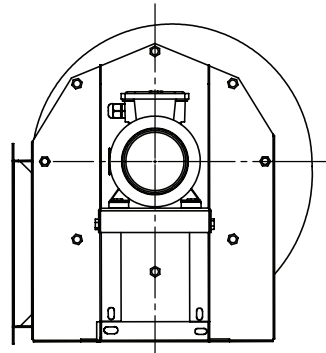

R270

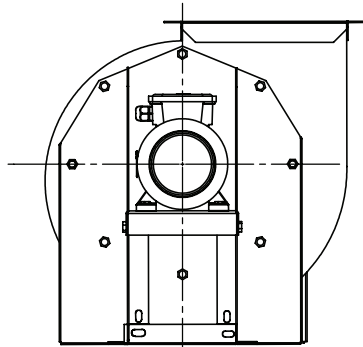

L090

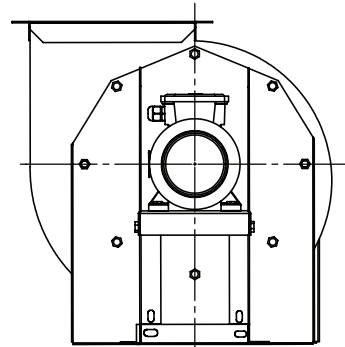

R090



RTRD

GERİYE EĞİMLİ VE ŞEYREK KANATLI, DİREKT AKUPLE, TEK EMİŞLİ, RADYAL FANLAR

SINGLE SUCTION, INDUSTRIAL RADIAL FANS (BACKWARD CURVED)

RTRD serisi fanlar, tek emişli geriye eğimli seyrek kanatlı radyal fanlardır. Yüksek verimli aşırı yüklemesiz 2.750 m³/h ile 23.500 m³/h debileri arasında ticari ve endüstriyel HVAC sistemlerinde emme ve basma uygulamaları için kullanılabilirler. Düşük enerji ile maksimum verim sağlarlar.

MALZEME

Gövdesi; Galvaniz sacdan üretilmiştir. Radyal Fan, geriye eğimli kanat yapısında DKP sacdan kaynaklı olarak imal edilmiştir. Mil; ST-45 çelikten imal edilmiştir. Yataklar; Kendini sürekli yenileyen rulmanlardan imal edilir.

HIZ KONTROLÜ

Kayış kasa sistemiyle elde edilir.

KULLANIM ALANLARI

İş yerleri, ofisler, kafeteryalar, restoranlar, toplantı salonları, süpermarketler vb. sessizlik ve konfor gerektiren yerlerde tercih edilir.

RTRD series fans, single suction Back Curved sparse blade radial fans. High efficiency overload 2.750 m³ / h and 23.500 m³/h flow rates between commercial and industrial HVAC suction and compression in systems they can be used for applications. Maximum efficiency with low energy they provide.

MATERIAL

Body; It is made of galvanized sheet. Radial Fan, backward curved blade structure It is made of welded DKP sheet metal. Shaft; Made of ST-45 steel. Beds ; Constantly renewing itself It is made of bearings.

SPEED CONTROL

Obtained by belt-pulley system.

USAGE AREAS

This type of fans is dusty and has particles inside containing air, sawdust, wood and metal shavings. However, cement, ceramic, feed factories, textile, chemical industries for pneumatic conveying and all that need to move from place to place used in applications.

Tip/Kod Type/Code	Elektrik Motoru / Electrical Motor				Max. Debi Air Flow m ³ / h	Max. Basınç Kaybı Pressure Pa
	Voltaj Voltage	Güç Power		Devir Speed		
	(V)	(HP)	(kW)	(d/d) (rpm)		
RTRD-250	380	4,00	3,00	4.400	2.750	2.100
RTRD-280	380	5,50	4,00	3.900	3.750	2.100
RTRD-315	380	5,50	4,00	3.400	5.700	2.050
RTRD-355	380	7,50	5,50	3.100	7.500	2.200
RTRD-400	380	7,50	5,50	2.600	9.250	1.900
RTRD-450	380	10,00	7,50	2.300	11.500	1.900
RTRD-500	380	10,00	7,50	2.050	15.000	1.850
RTRD-560	380	15,00	11,00	1.900	20.000	1.950
RTRD-630	380	15,00	11,00	1.600	23.500	1.800



RTRD - 250

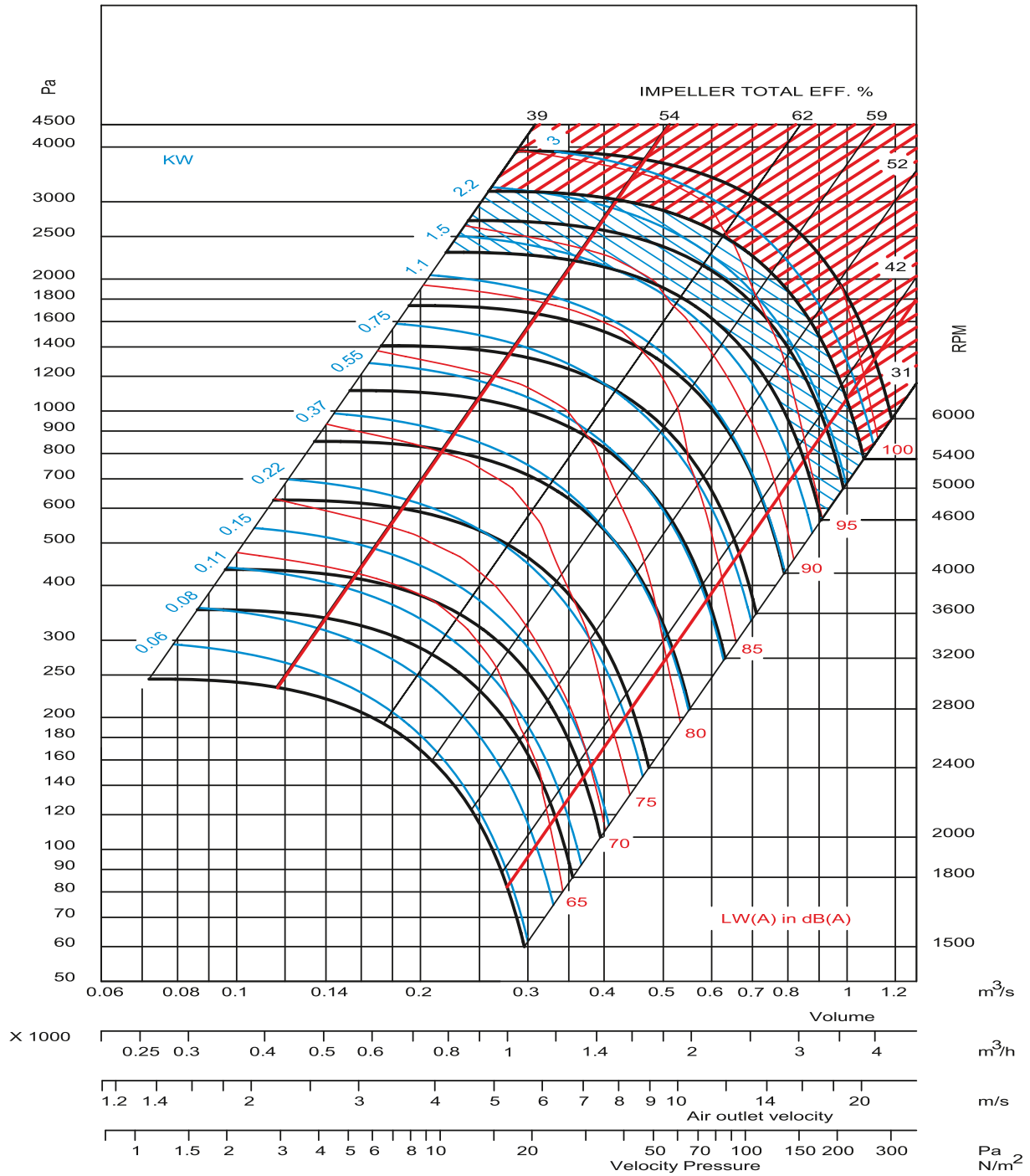

RTRD - 280

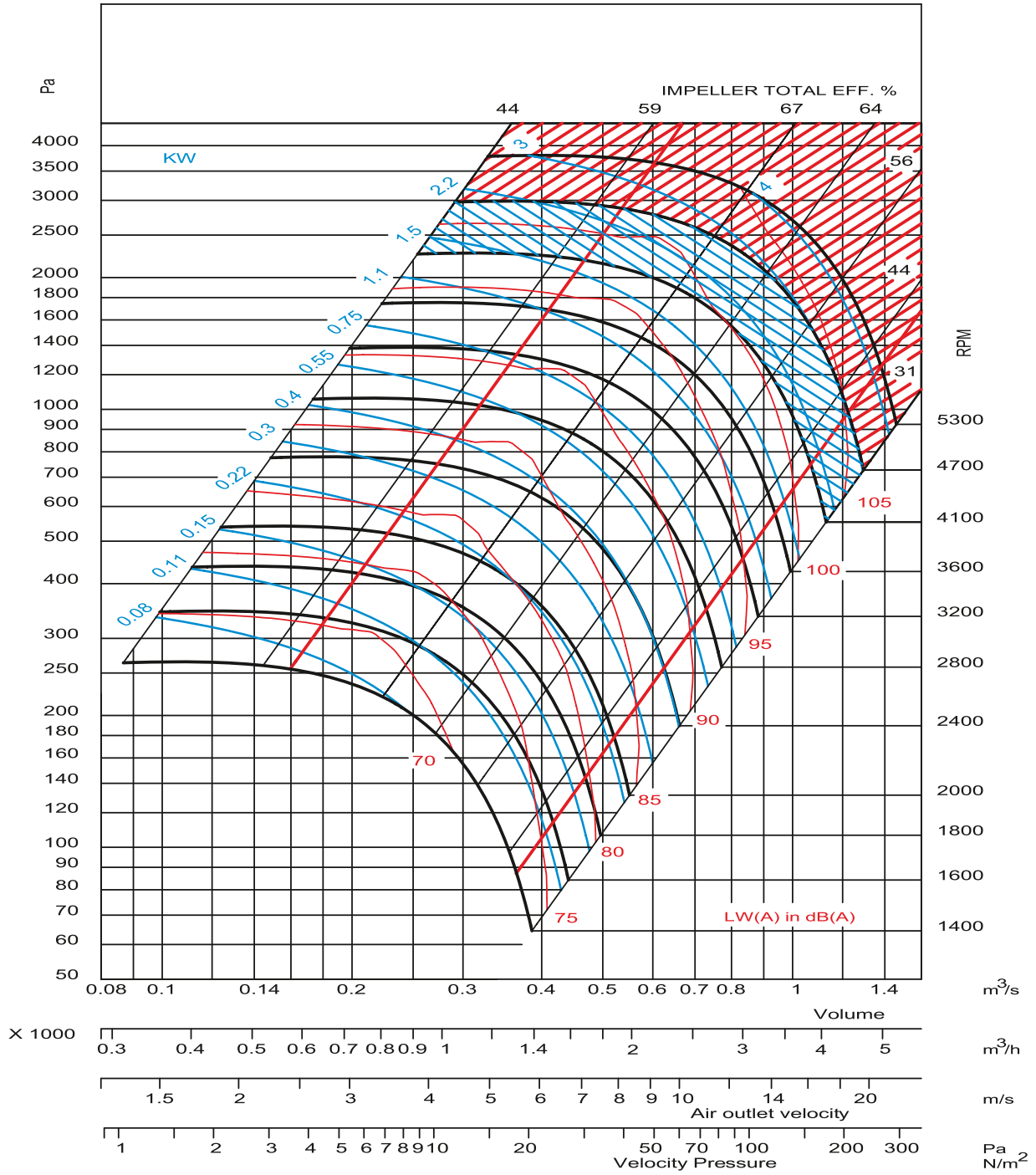



RTRD - 315

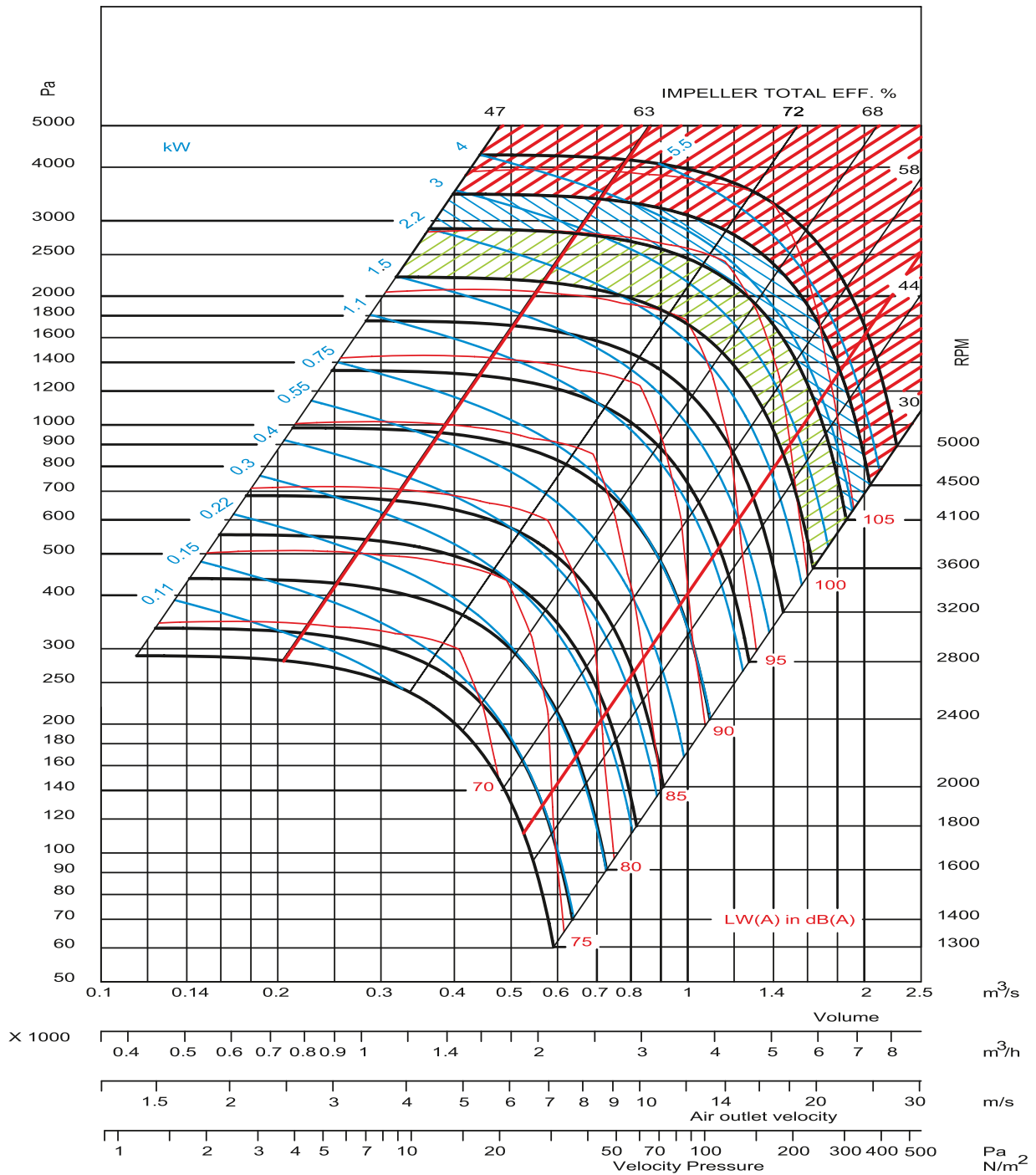

3 RADYAL FANLAR RADIAL FANS



RTRD - 355

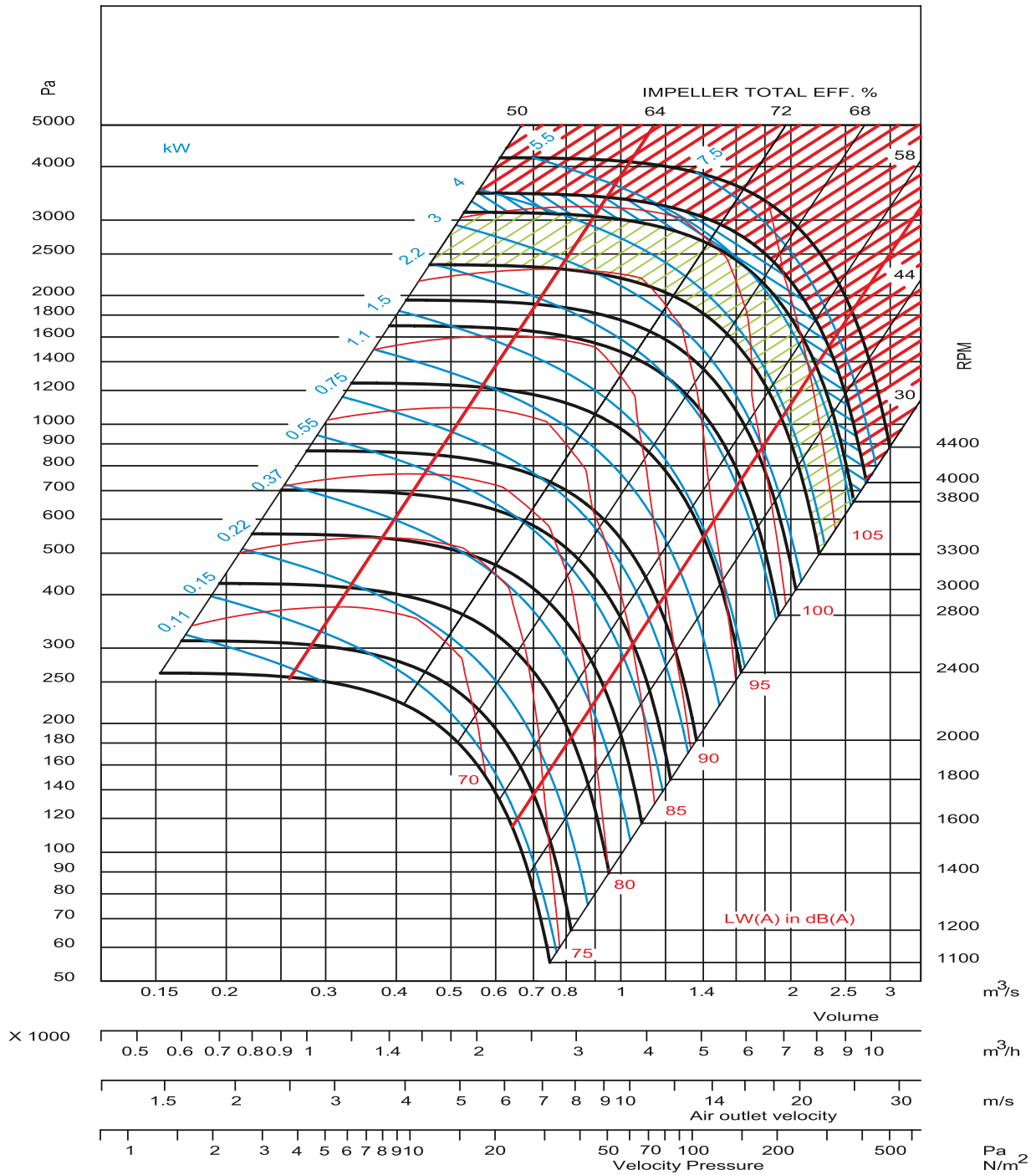

Discover the potential



RTRD - 400

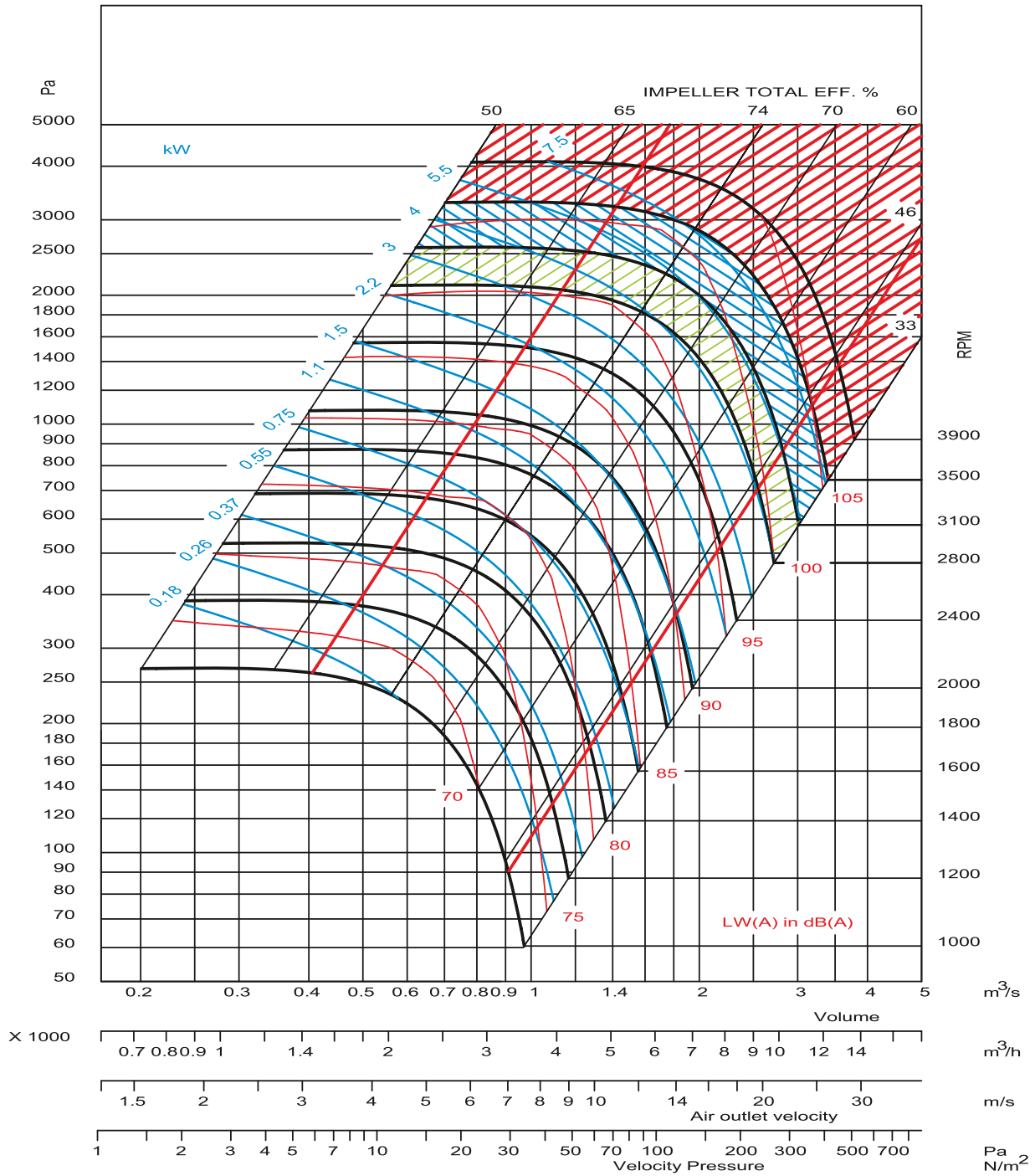

3 RADYAL FANLAR RADIAL FANS



RTRD - 450

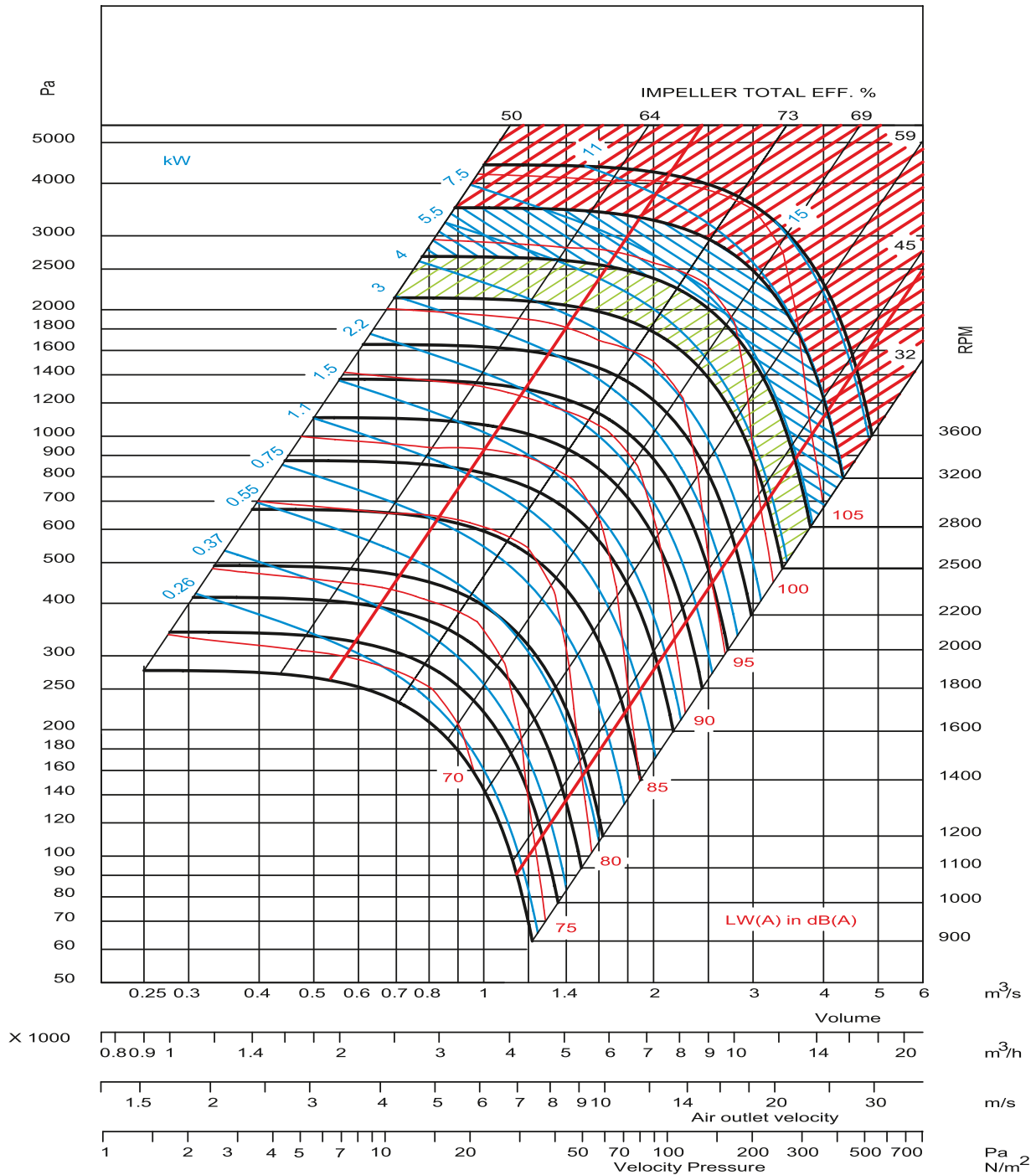

Discover the potential



RTRD - 500

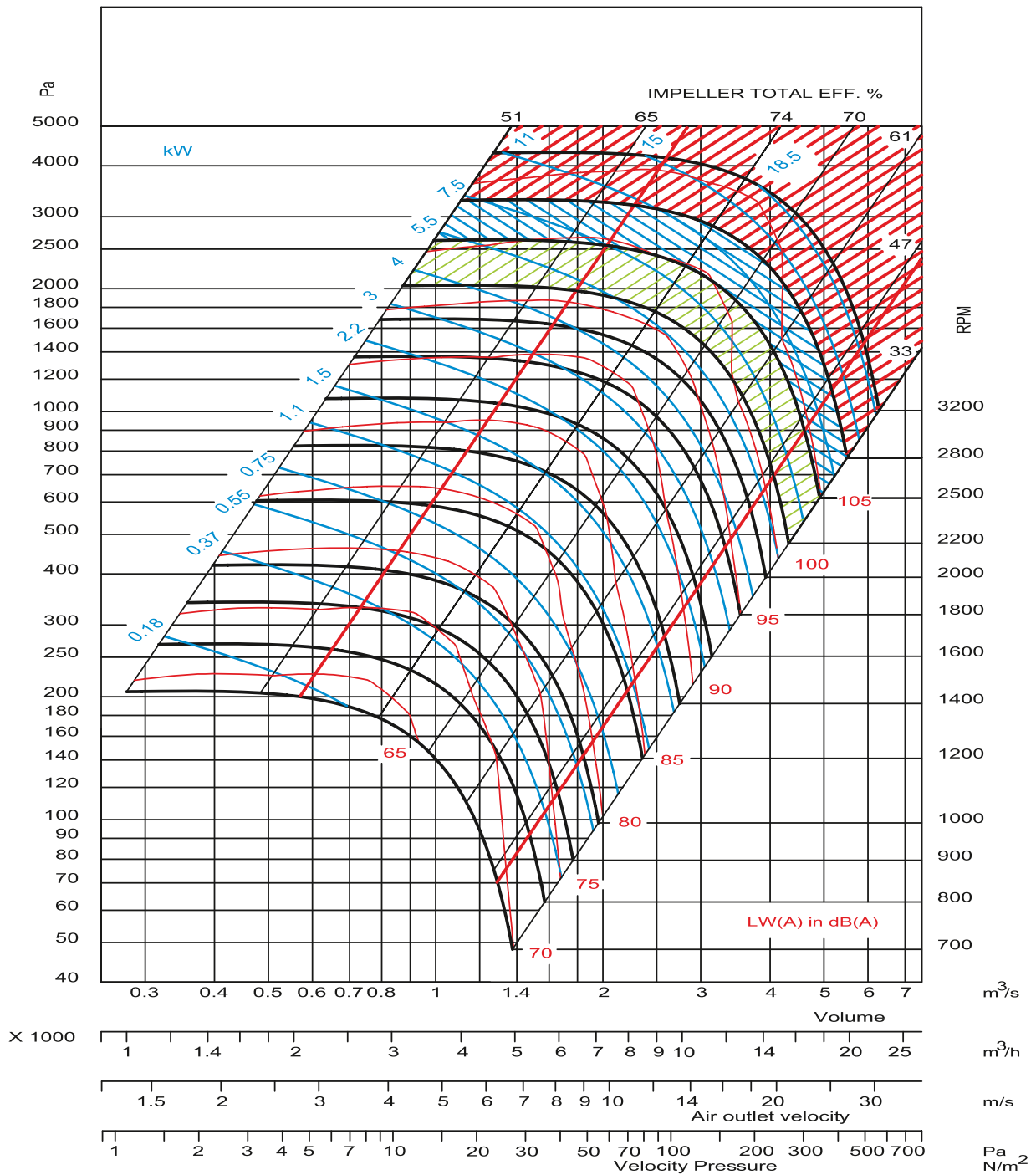

RTRD - 560

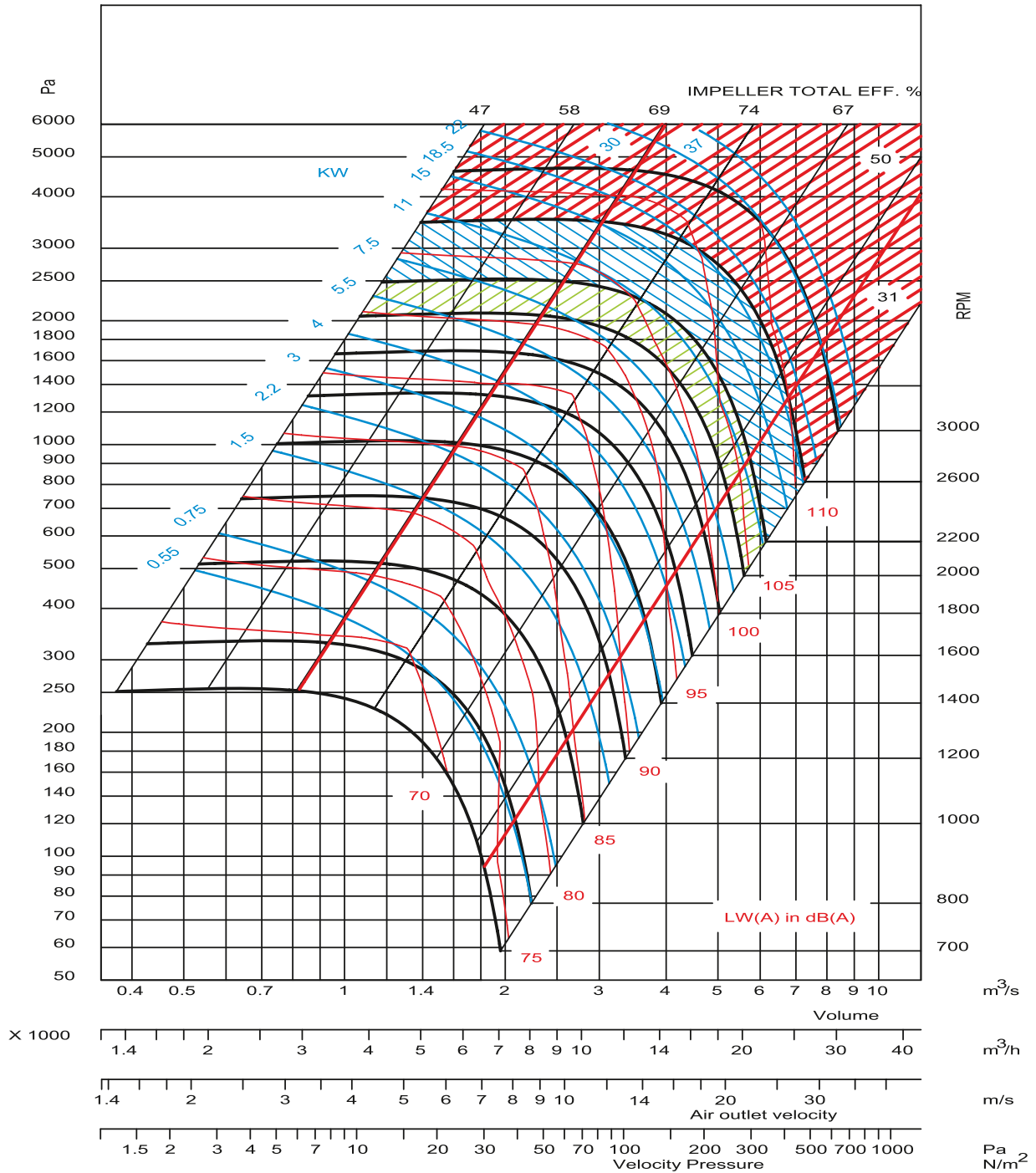

Discover the potential



RTRD - 630

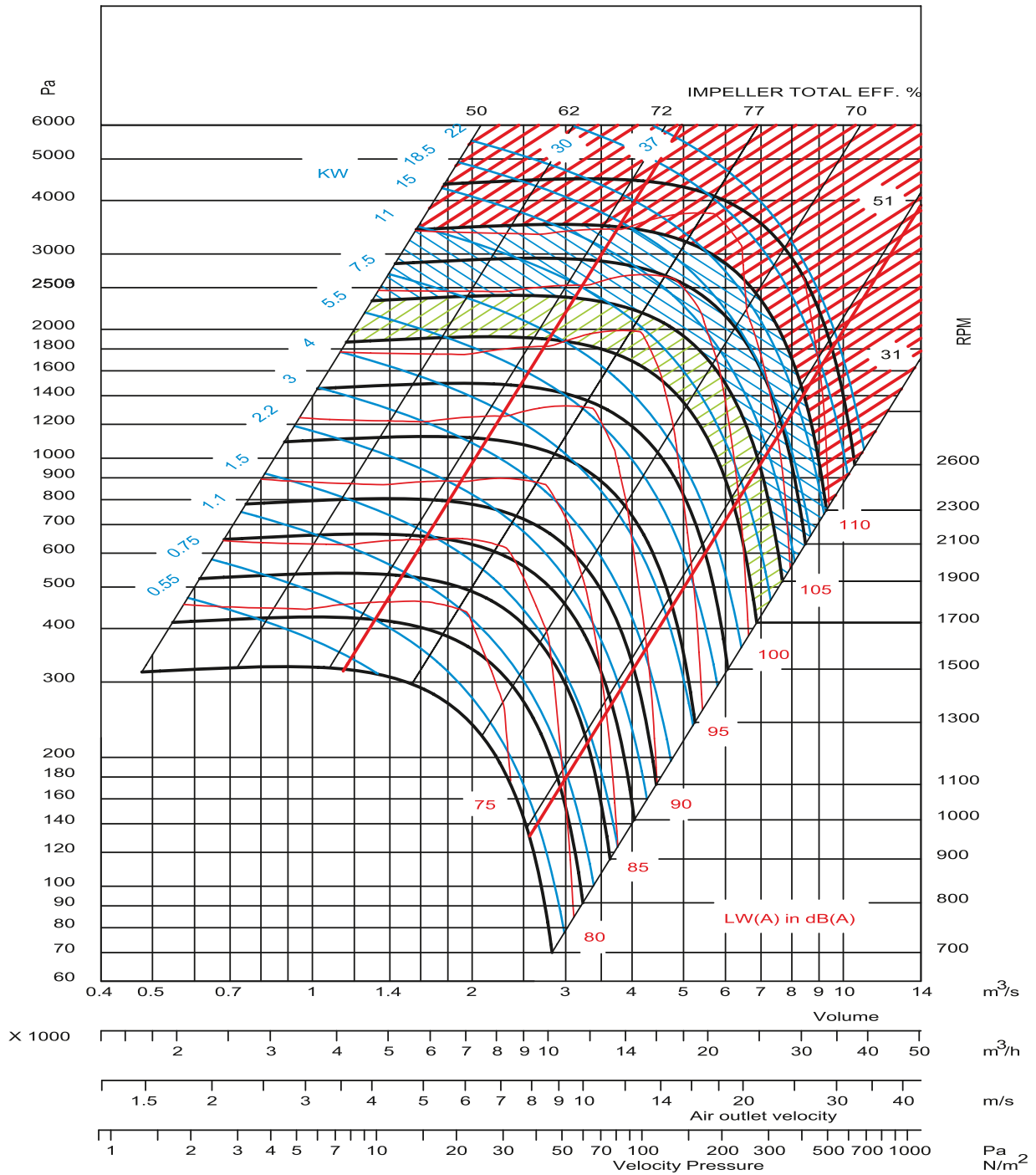

ACTIVENT®

Halkalı Merkez Mahallesi
Şehit Yılmaz Özdemir Caddesi
Sanayi Sokak No: 4
Küçükçekmece, İstanbul, Türkiye

P: +90.212 698 02 25

P: +90.212 698 02 26

P: +90.212 565 73 03

info@activent.com.tr

www.activent.com.tr

