

GÜÇLÜ BİR GELECEK İÇİN STRONGER FOR THE FUTURE



www.activent.com.tr



ACTIVENT®

ÜRÜN KATALOĞU
PRODUCT CATALOGUE



RADYAL FANLAR
RADIAL FANS

RADYAL FAN YÖNLERİ RADIAL FAN DIRECTIONS

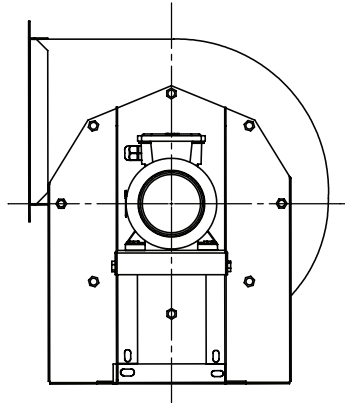

L180

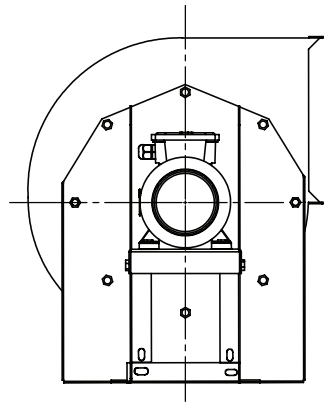

R180

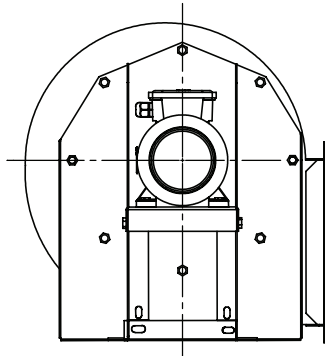

L270

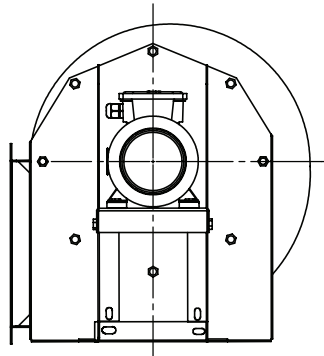

R270

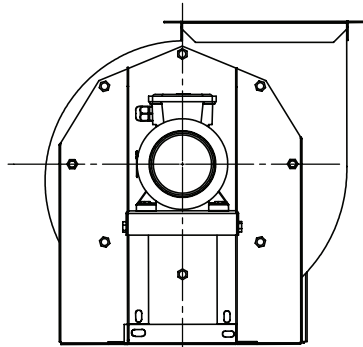

L090

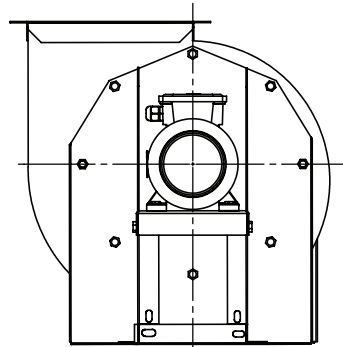

R090

3 RADYAL FANLAR RADIAL FANS



RTAD

ÖNE EĞİMLİ VE SIK KANATLI DİREKT AKUPLE,
TEK EMİŞLİ, RADYAL FAN

SINGLE SUCTION INDUSTRIAL RADIAL FANS
(FORWARD CURVED) LOW PRESSURE

RTAD serisi fanlar, tek emişli öne eğimli sık kanatlı radyal fanlardır. Yüksek verimli aşırı yüklemesiz 4.750 m³/h ile 29.000 m³/h debileri arasında ticari ve endüstriyel HVAC sistemlerinde emme ve basma uygulamaları için kullanılabilirler. Düşük enerji ile maksimum verim sağlarlar.

MALZEME

Gövdesi; Galvaniz sacdan üretilmiştir. Radyal Fan, öne eğimli kanat yapısında DKP sacdan kaynaklı olarak imal edilmiştir.

Mil; ST-45 çelikten imal edilmiştir. Yataklar; Kendini sürekli yenileyen rulmanlardan imal edilir.

HIZ KONTROLÜ

Opsiyonel olarak frekans inverteri ile sağlanabilirler.

KULLANIM ALANLARI

İş yerleri, ofisler, kafeteryalar, restoranlar, toplantı salonları, süpermarketler vb. sessizlik ve kontrol gerektiren yerlerde tercih edilir.

RTAD series fans are single inlet one inclined dense bladed radial fans. High efficiency overload Flow rates of 4,750 m³/h and 29,000 m³ / h between commercial and industrial HVAC suction and compression in systems they can be used for applications. Maximum efficiency with low energy they provide.

MATERIAL

The body is made of galvanized sheet metal. The Radial Fan is welded from DKP sheet metal in a backward-inclined wing structure. The shaft is made of ST-45 steel. Bearings are manufactured from self-renewing bearings.

SPEED CONTROL

Obtained by belt-pulley system.

USAGE AREAS

This type of fans is dusty and has particles inside containing air, sawdust, wood and metal shavings. However, cement, ceramic, feed factories, textile, chemical industries for pneumatic conveying and all that need to move from place to place used in applications.

Tip/Kod Type/Code	Elektrik Motoru / Electrical Motor				Max. Debi Air Flow m ³ / h	Max. Basınç Kaybı Pressure Pa
	Voltaj Voltage (V)	Güç Power (HP) (kW)		Devir Speed (d/d) (rpm)		
RTAD-250	380	5,50	4,00	2.800	4.750	1.900
RTAD-280	380	7,50	5,50	2.500	6.000	2.050
RTAD-315	380	7,50	5,50	2.200	7.500	2.100
RTAD-355	380	10,00	7,50	1.950	9.500	2.150
RTAD-400	380	10,00	7,50	1.800	11.500	2.100
RTAD-450	380	15,00	11,00	1.500	15.000	1.850
RTAD-500	380	15,00	11,00	1.200	18.500	1.500
RTAD-560	380	20,00	15,00	1.150	23.000	1.650
RTAD-630	380	20,00	15,00	1.050	29.000	1.800

Discover the potential



RTAD - 250

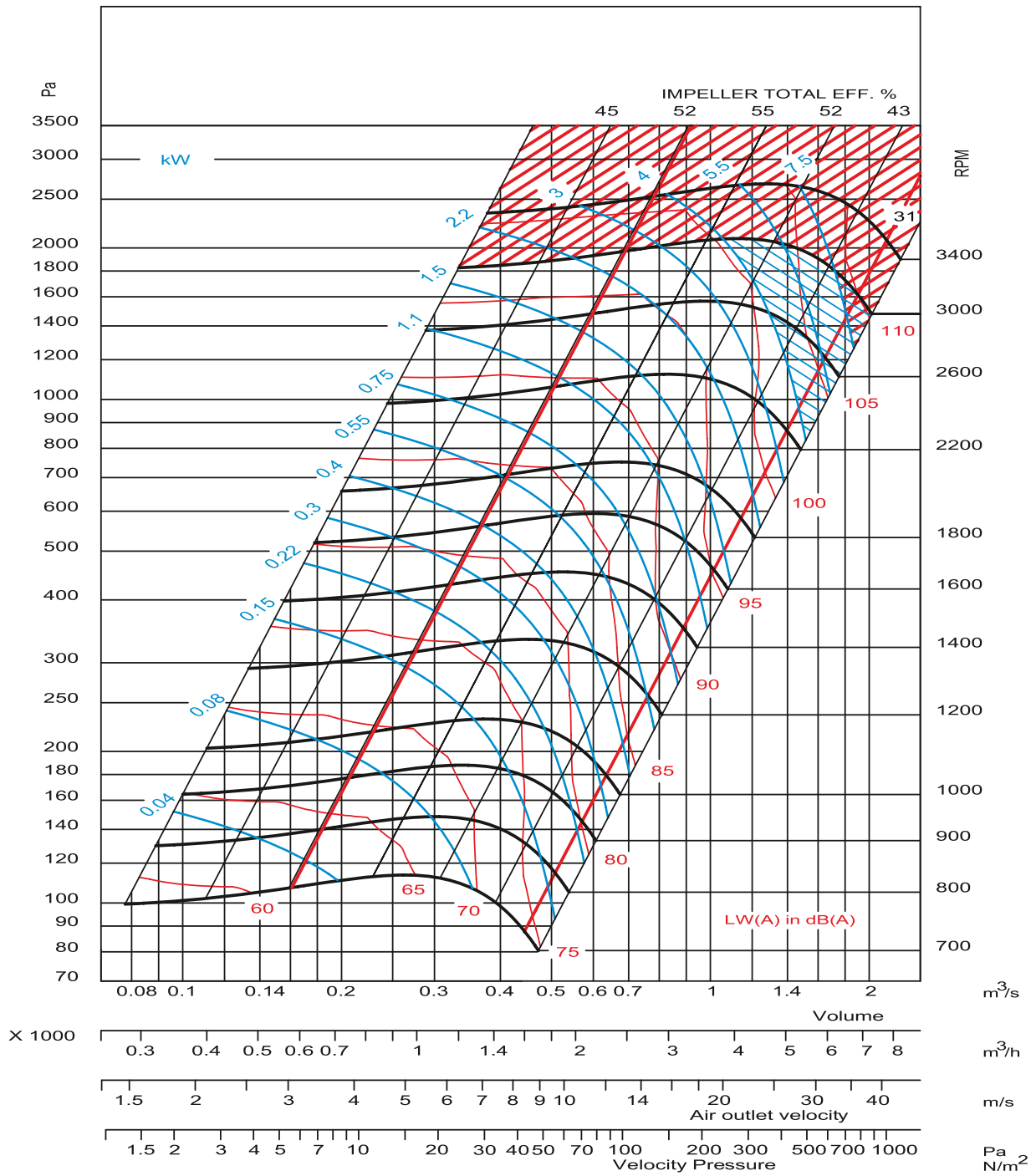

RTAD - 280

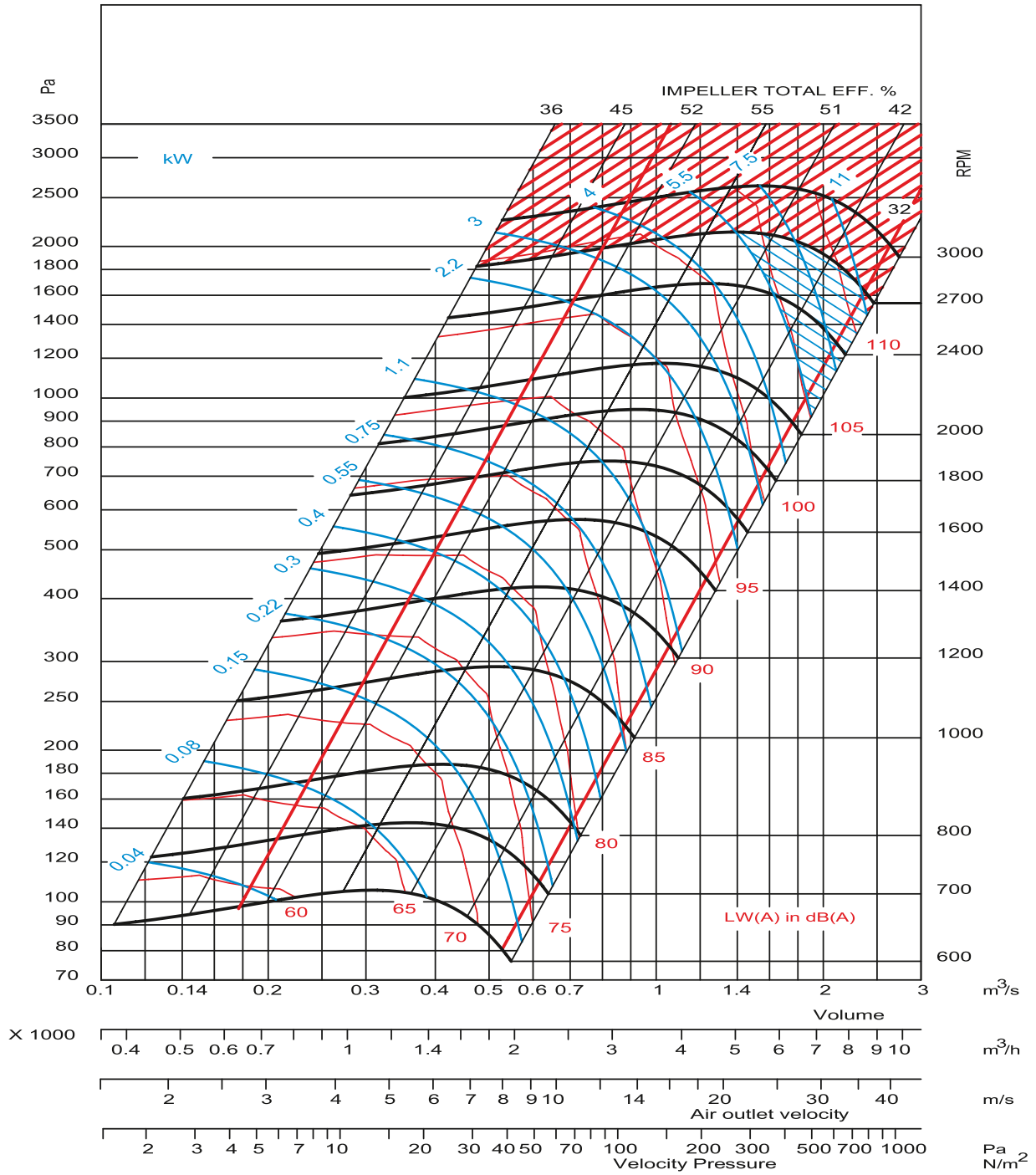

Discover the potential



RTAD - 315

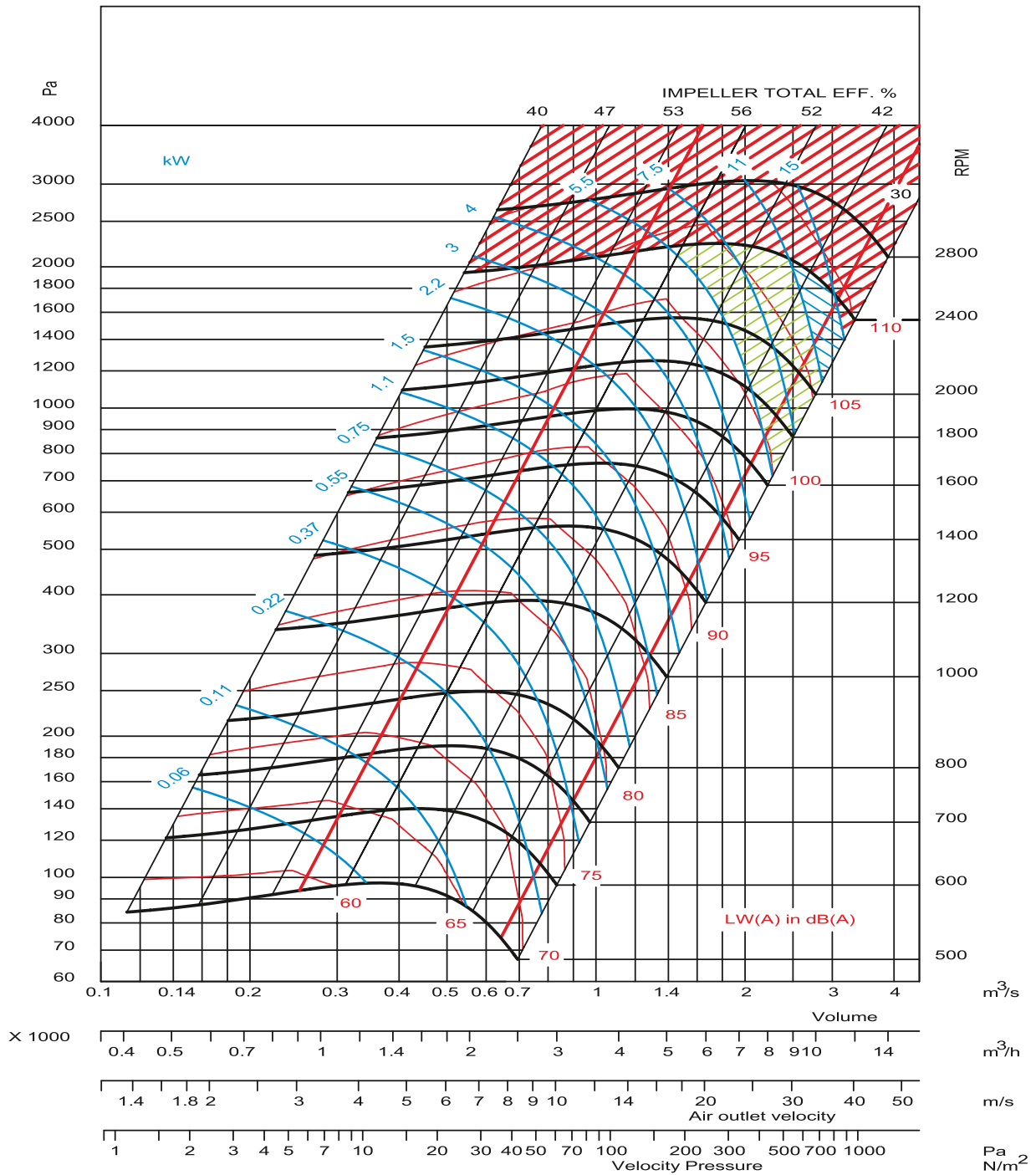

3 RADYAL FANLAR RADIAL FANS



RTAD - 355

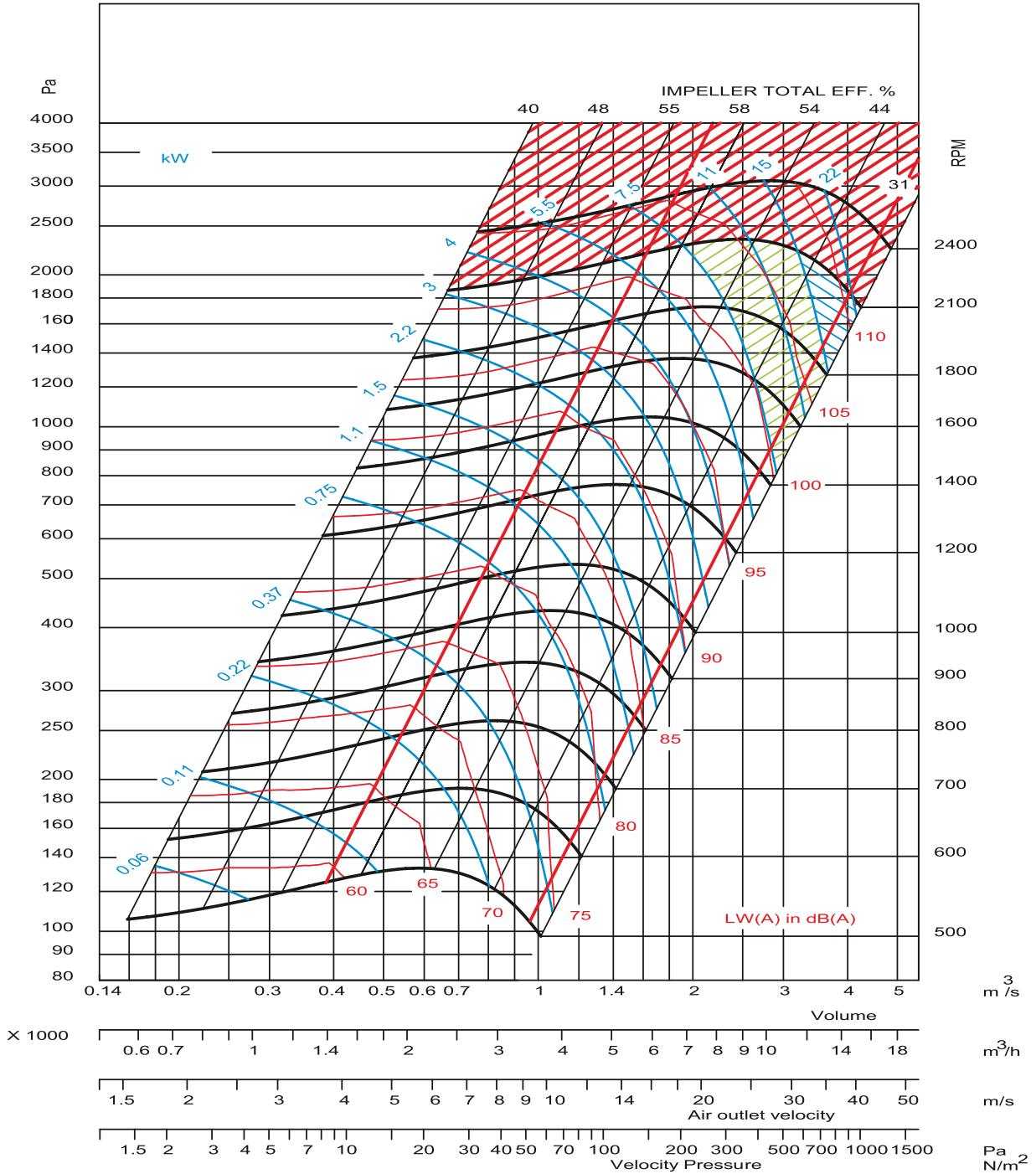



RTAD - 400

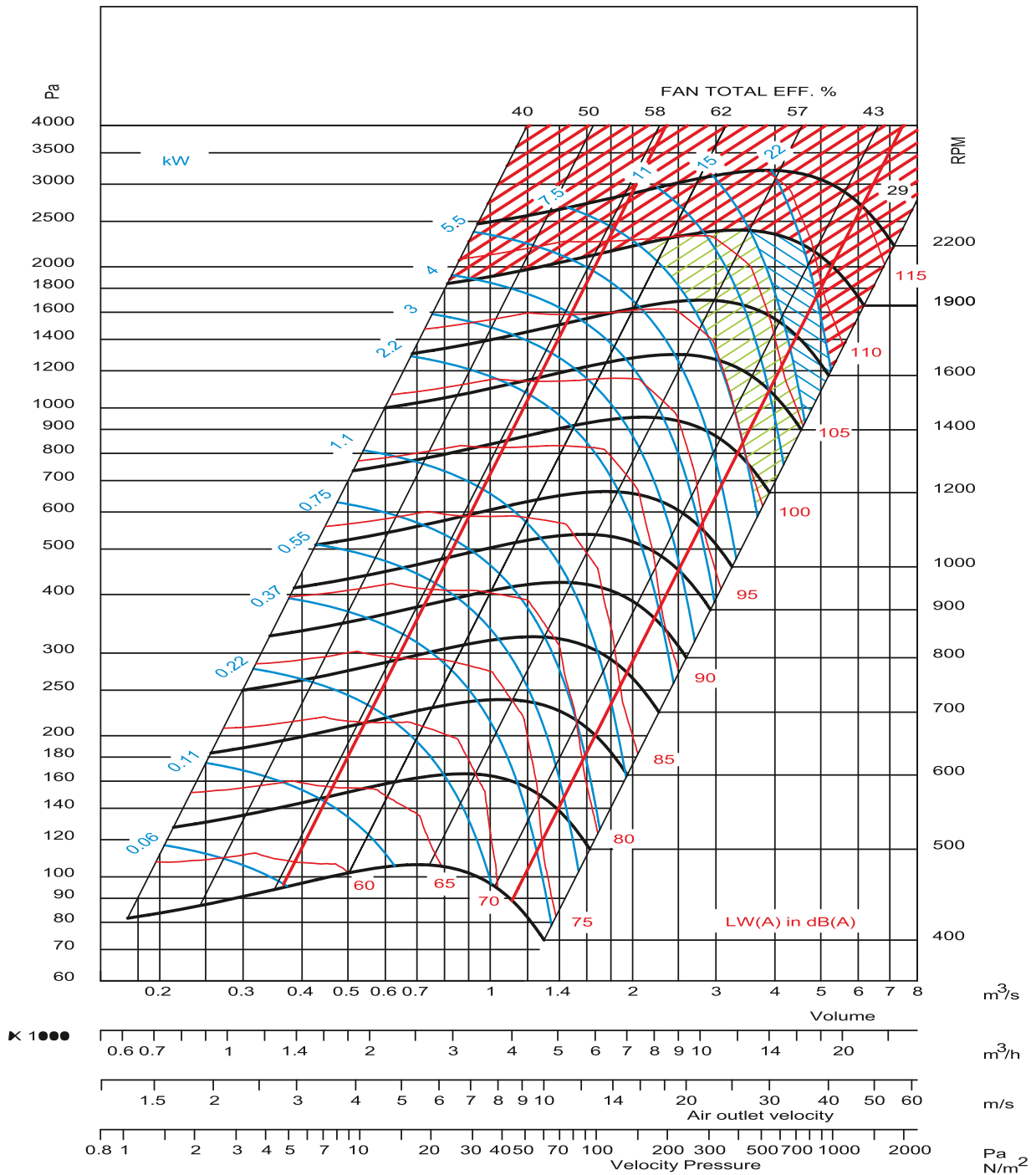

3 RADYAL FANLAR RADIAL FANS



RTAD - 450

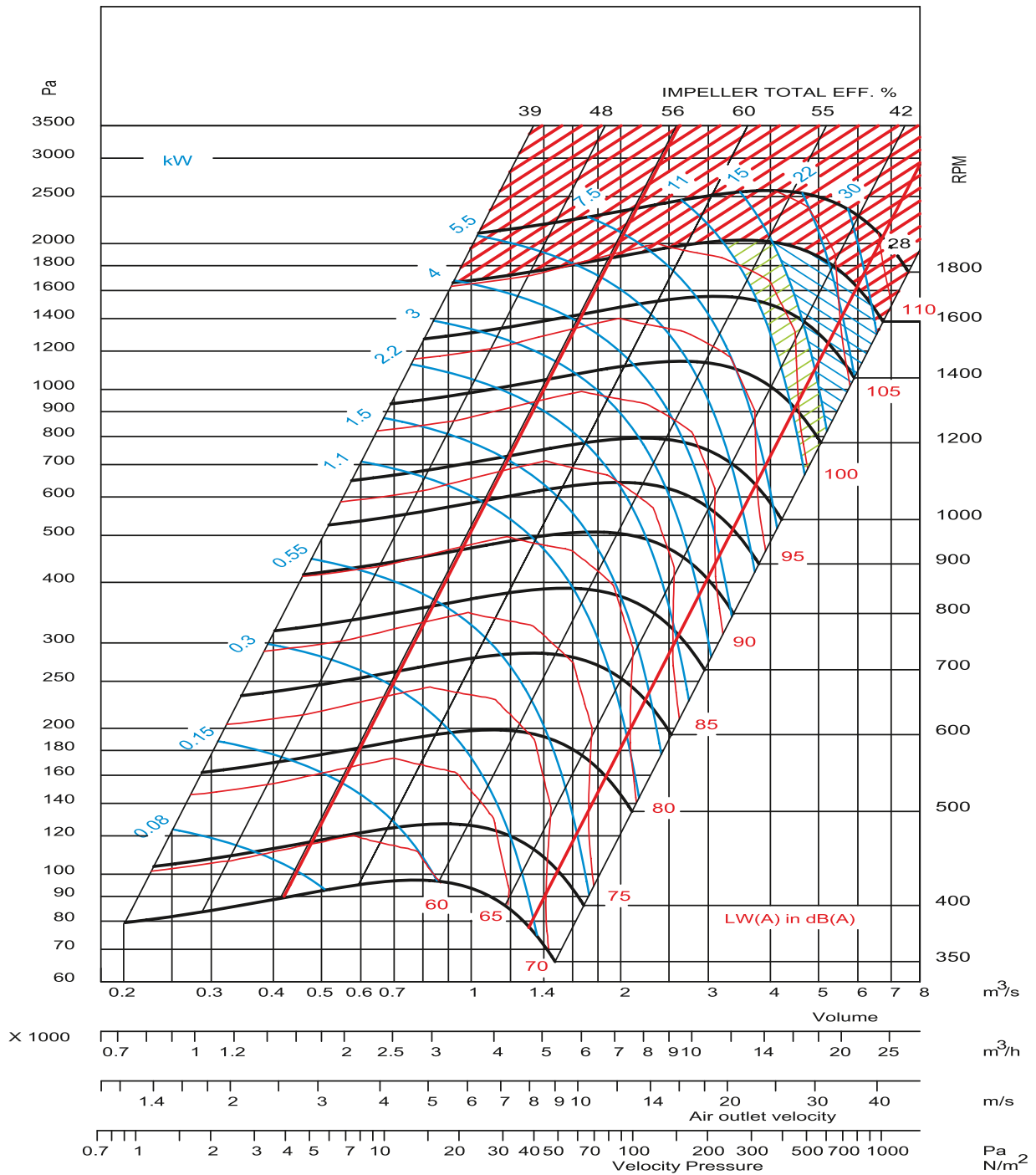

Discover the potential



RTAD - 500

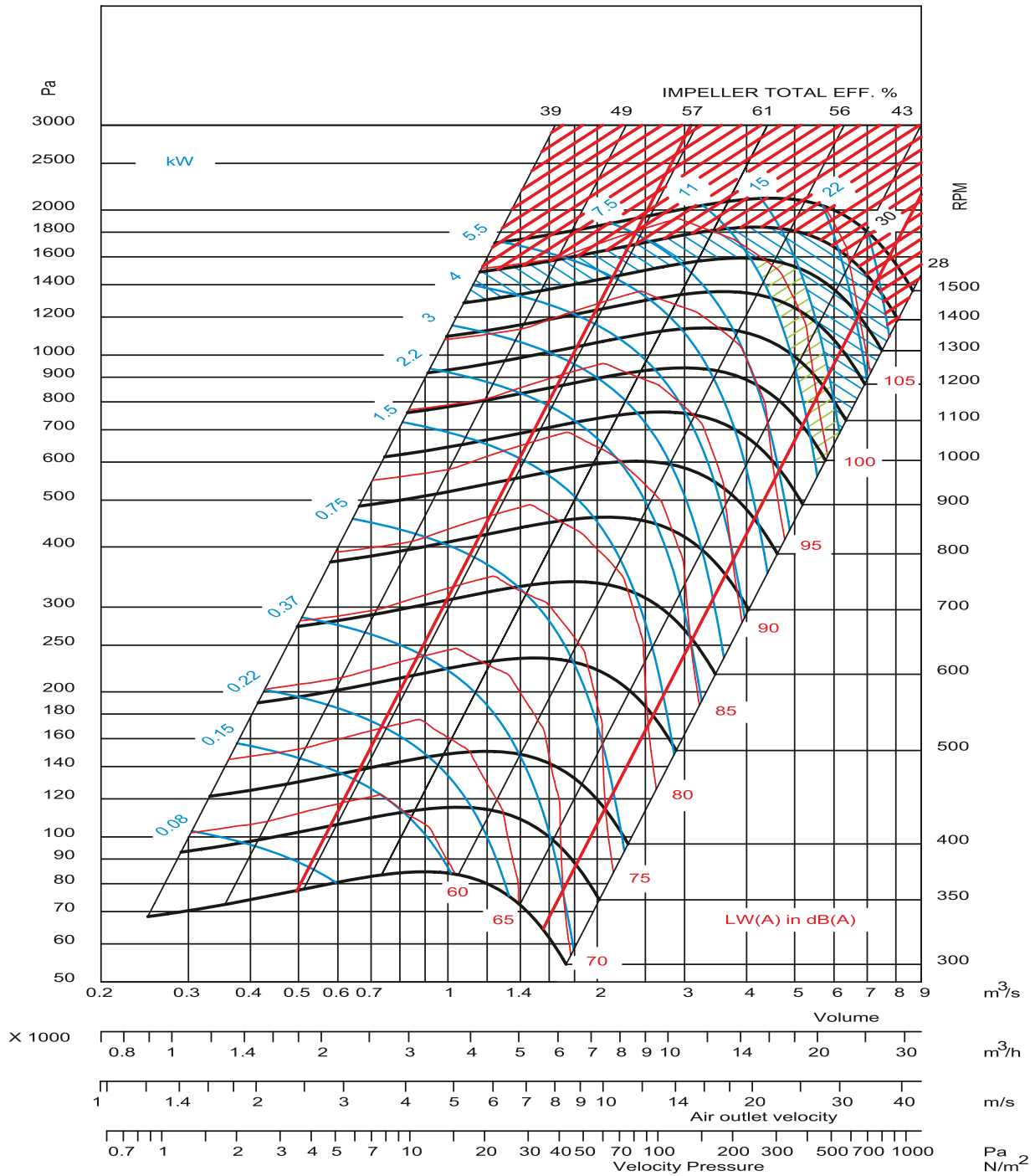

RTAD - 560

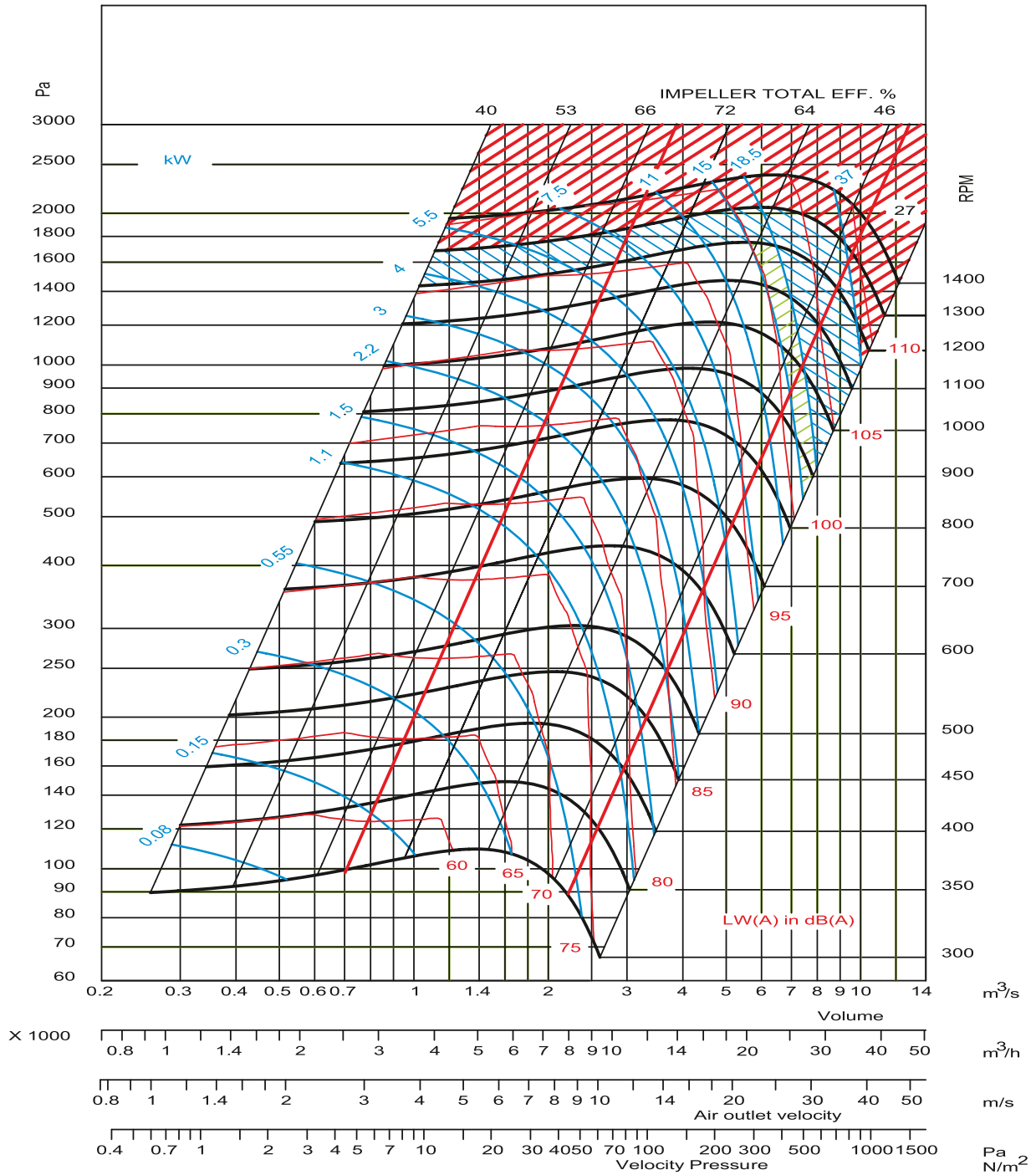

Discover the potential



RTAD - 630

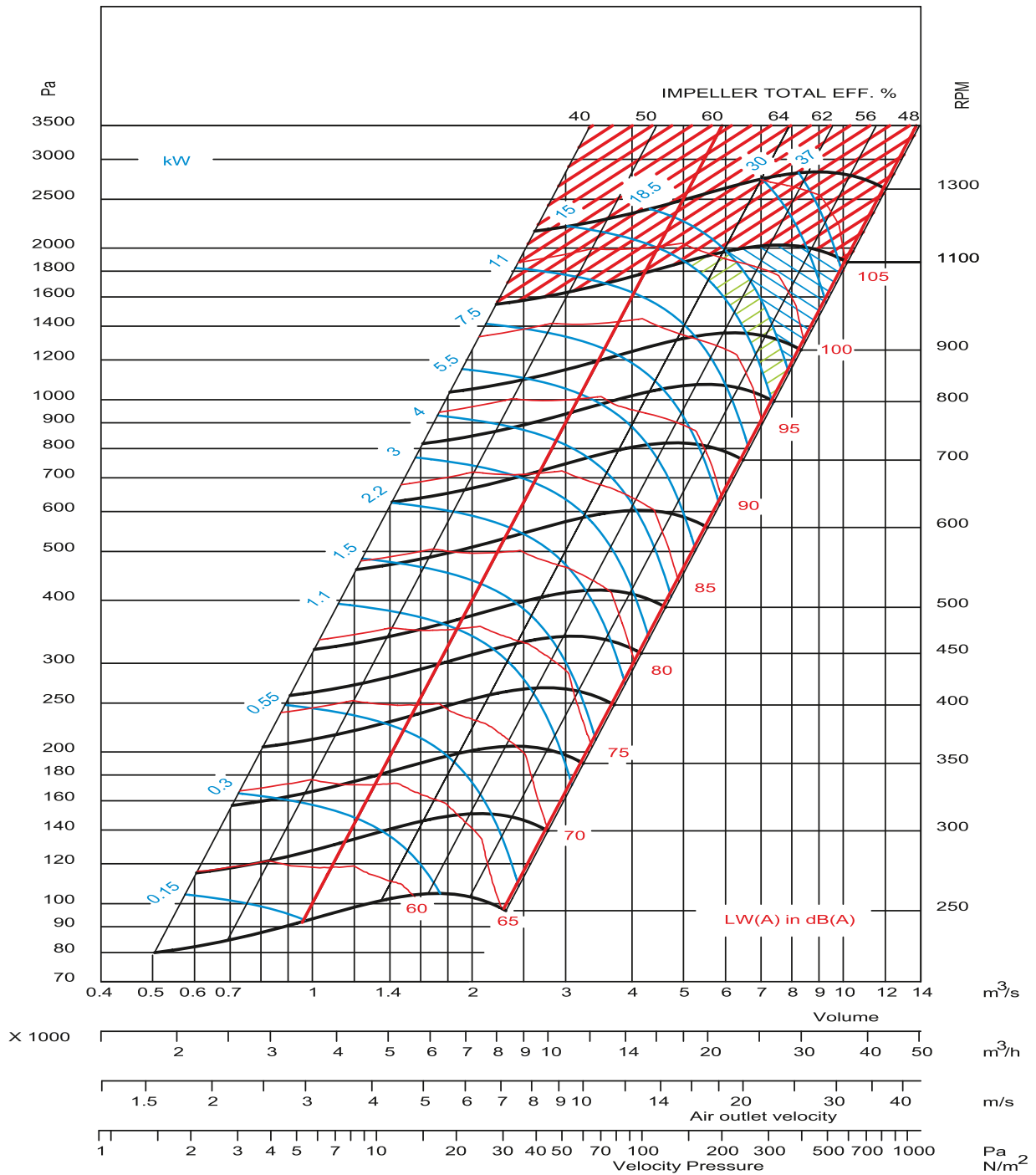

ACTIVENT®

Halkalı Merkez Mahallesi
Şehit Yılmaz Özdemir Caddesi
Sanayi Sokak No: 4
Küçükçekmece, İstanbul, Türkiye

P: +90.212 698 02 25

P: +90.212 698 02 26

P: +90.212 565 73 03

info@activent.com.tr

www.activent.com.tr

