

GÜÇLÜ BİR GELECEK İÇİN STRONGER FOR THE FUTURE



www.activent.com.tr



ACTIVENT®

ÜRÜN KATALOĞU
PRODUCT CATALOGUE



RCAD

ÖNE EĞİMLİ VE SIK KANATLI, ÇİFT EMİŞLİ,
HÜCRE İÇ FANI RADYAL FANLAR

DOUBLE SUCTION, CELL INTERNAL FAN
RADIAL FANS (FORWARD CURVED)

RCAD serisi fanlar, çift emişli öne eğimli sık kanatlı radyal fanlardır. Yüksek verimli aşırı yüklemesiz 6.000 m³/h ile 47.000 m³/h debileri arasında ticari ve endüstriyel HVAC sistemlerinde emme ve basma uygulamaları için kullanılabilirler. Düşük enerji ile maksimum verim sağlarlar.

MALZEME

Gövdesi; Galvaniz sacdan üretilmiştir. Radyal Fan, öne eğimli kanat yapısında ST-37 DKP sacdan elektrostatik boyalı imal edilmiştir. Mil; ST-45 çelikten imal edilmiştir.

HIZ KONTROLÜ

Kayış kasnak sistemiyle elde edilir.

KULLANIM ALANLARI

Hücreli aspiratörler, merkezi klima üniteleri, iş yerleri, ofisler, kafeteryalar, restoranlar, toplantı salonları, süpermarketler vb. sessizlik ve konfor gerektiren yerlerde tercih edilir.

RCAD series fans, double suction front inclined dense bladed radial fans. High efficiency without overload. Flow rates of 6.000 m³/h and 47.000 m³/h between commercial and industrial HVAC suction and compression in systems They can be used for applications. Maximum efficiency with low energy they provide.

MATERIAL

Its body is made of galvanized sheet metal. The Radial Fan is made of electrostatically painted sheet metal ST-37 DKP in a forward-inclined wing structure. The shaft is made of ST-45 steel.

SPEED CONTROL

It is obtained with a belt-pulley system.

USAGE AREAS

Cell aspirators, central air conditioning units, workplaces, offices, cafeterias, restaurants, meeting rooms, supermarkets, etc. silence and reserved is preferred.

Tip/Kod Type/Code	Maks. Çalışma Şartları / Max. Working Conditions			Max. Debi Air Flow m ³ / h	Max. Basınç Kaybı Pressure Pa
	Voltaj Voltage	Güç Power	Devir Speed		
	(V)	(kW)	(d/d) (rpm)		
RCAD-280	380	5,50	2.300	7.700	2.100
RCAD-315	380	5,50	1.900	10.000	1.950
RCAD-355	380	7,50	1.600	12.900	1.800
RCAD-400	380	7,50	1.500	16.100	1.850
RCAD-450	380	11,0	1.300	19.950	1.700
RCAD-500	380	11,0	1.100	26.900	1.450
RCAD-560	380	15,0	1.000	30.000	1.550
RCAD-630	380	15,0	850	37.500	1.400
RCAD-710	380	18,5	700	47.000	1.200

TEKNİK ÖLÇÜLER / TECHNICAL DIMENSION

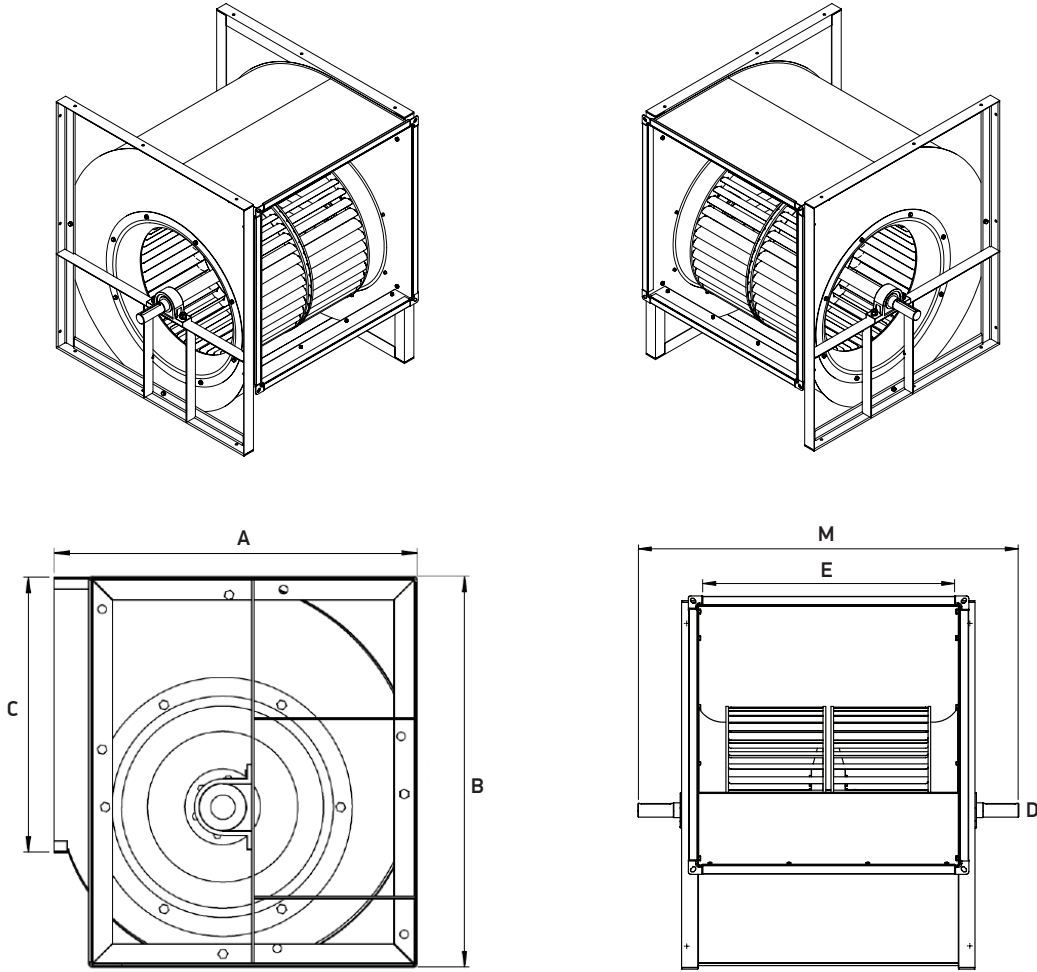

Tip/Kod Type/Code	Ölçüler / Sizes (mm)					
	A	B	C	D	E	M
RCAD-280	466	518	361	Ø 30	361	555
RCAD-315	518	578	404	Ø 30	404	600
RCAD-355	578	655	453	Ø 35	453	675
RCAD-400	649	736	507	Ø 35	507	725
RCAD-450	726	827	569	Ø 40	569	815
RCAD-500	800	918	638	Ø 40	638	885
RCAD-560	891	1.030	715	Ø 40	715	1.000
RCAD-630	996	1.157	801	Ø 40	801	1.085
RCAD-710	1.117	1.303	898	Ø 50	898	1.255

RCAD - 280

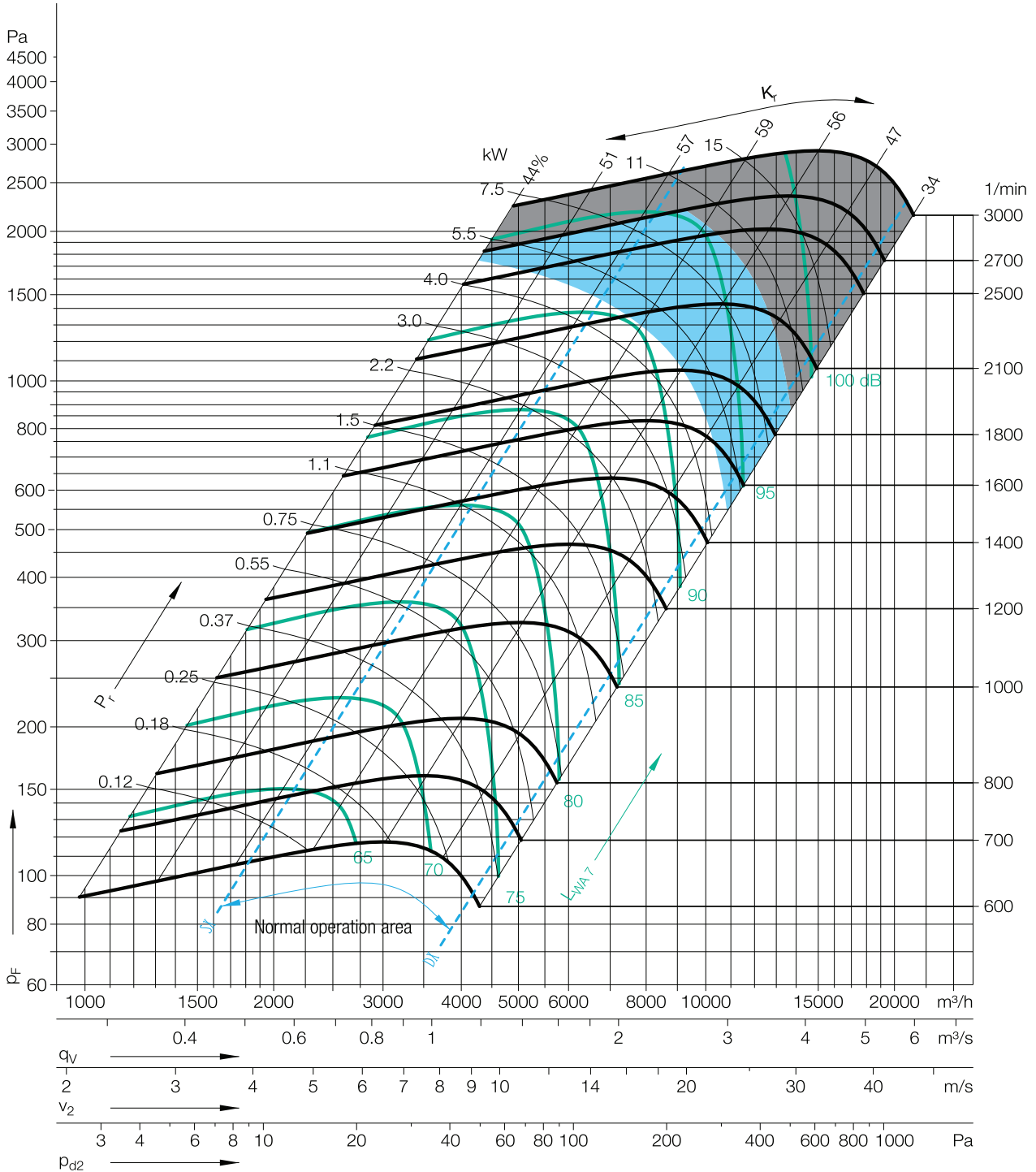



RCAD - 315

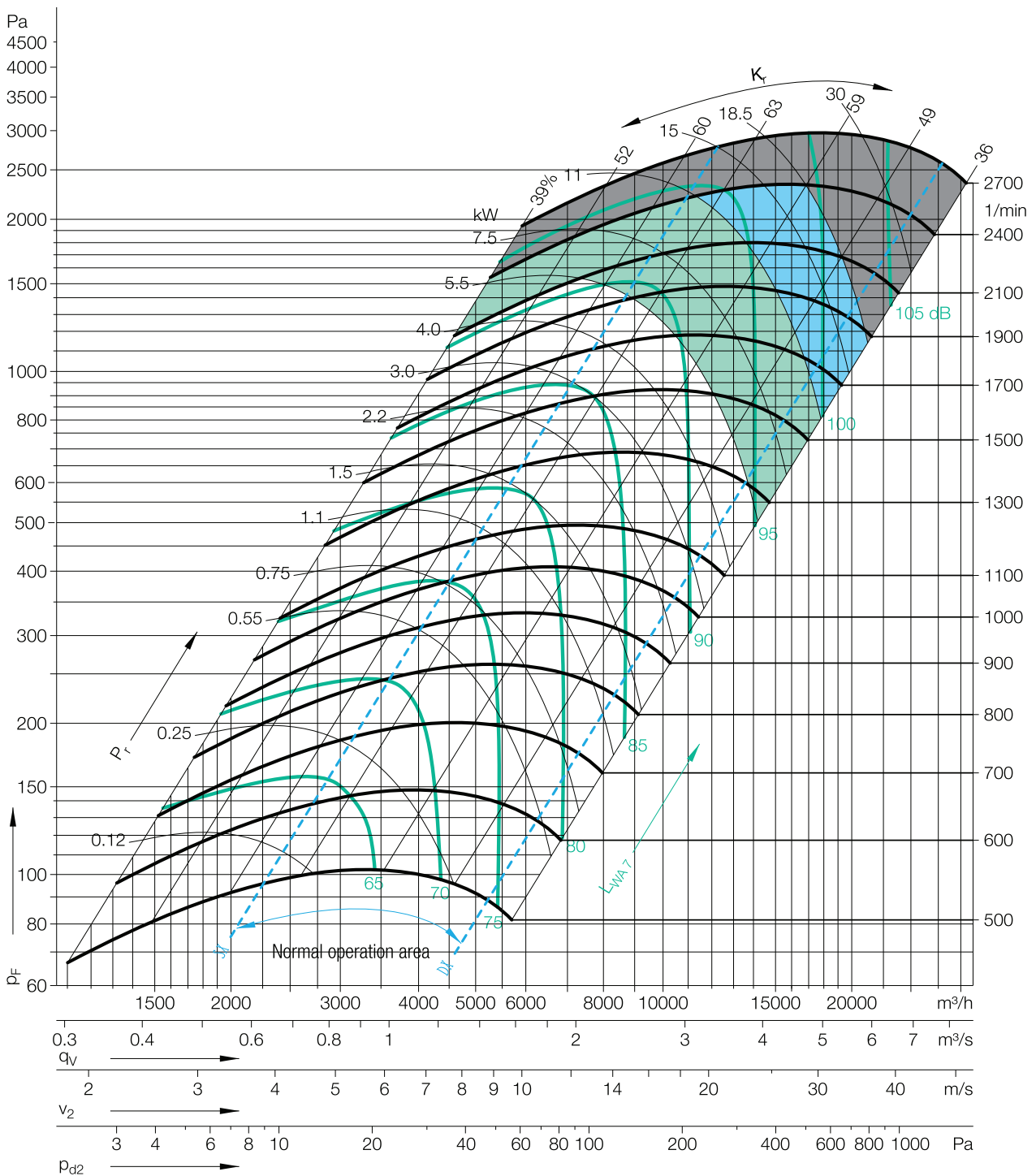

RCAD - 355

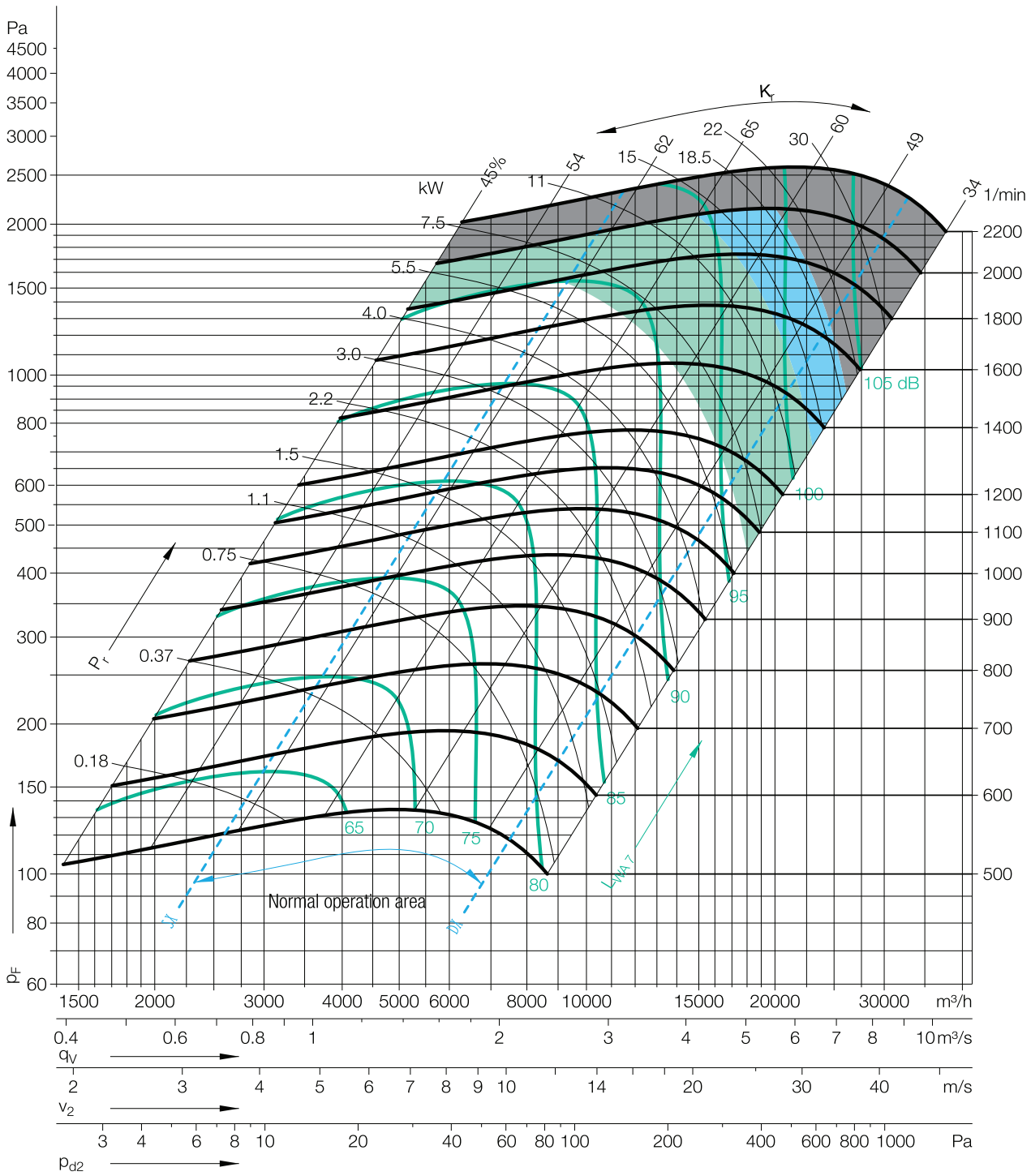



RCAD - 400

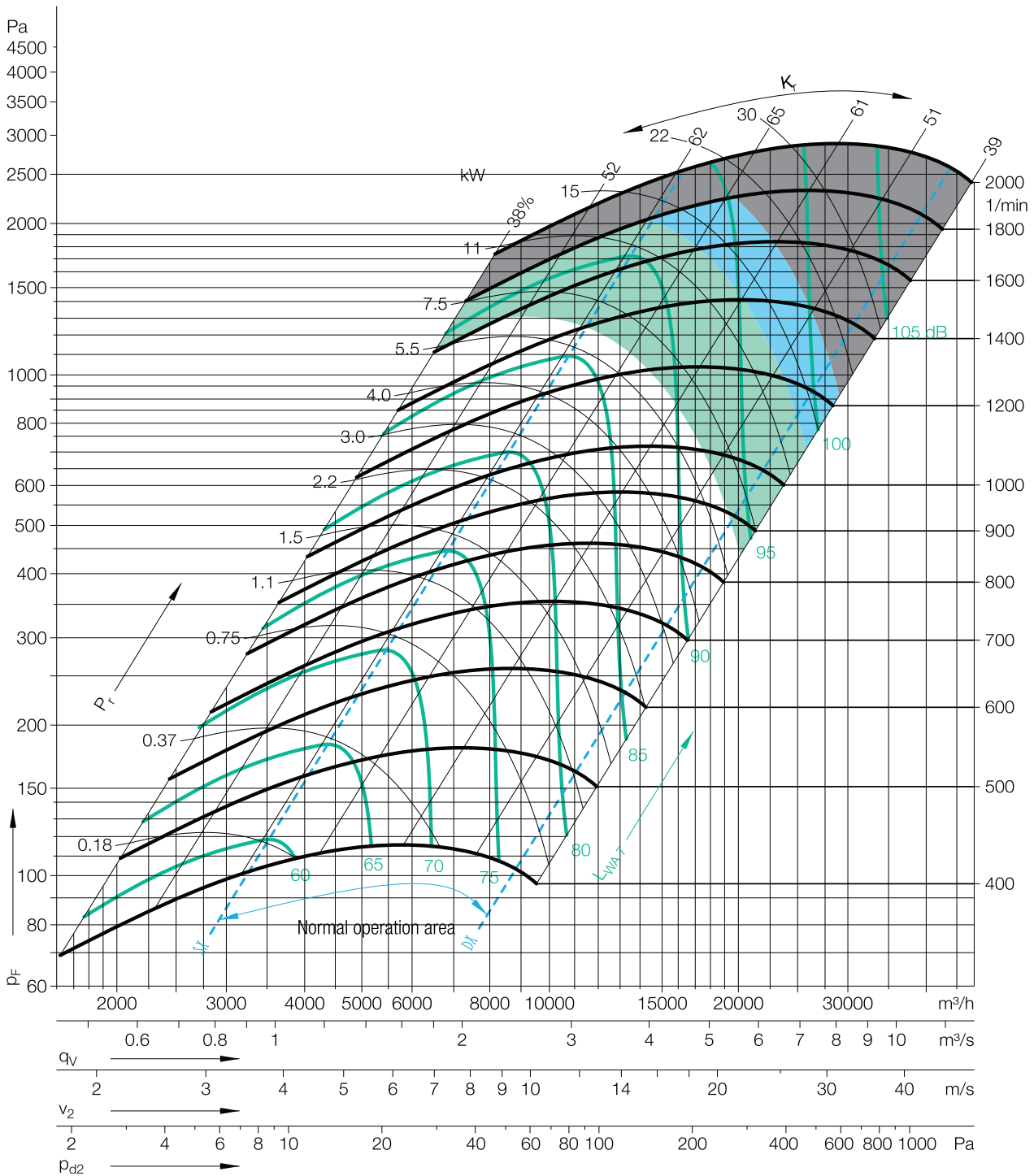

RCAD - 450

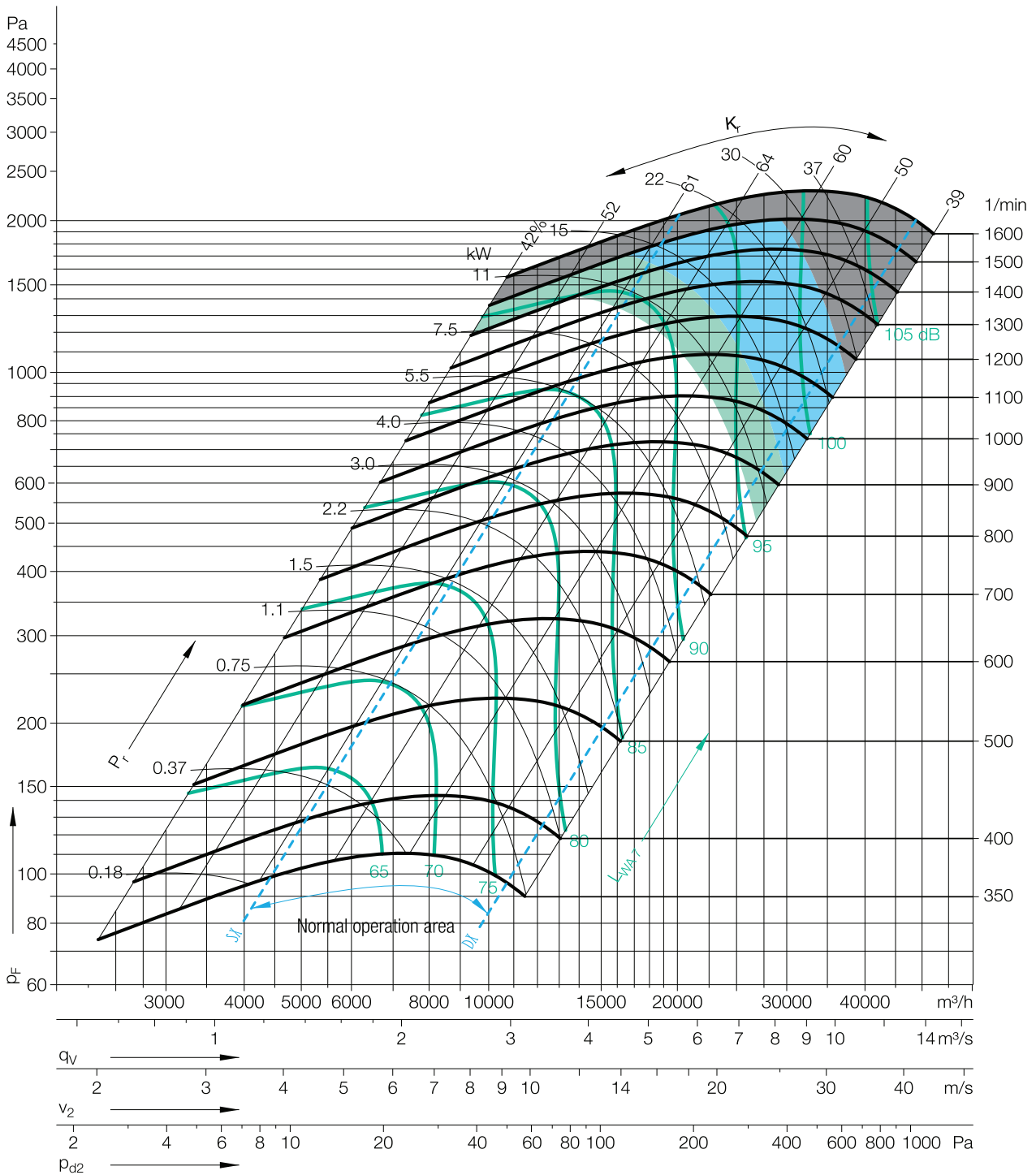



RCAD - 500

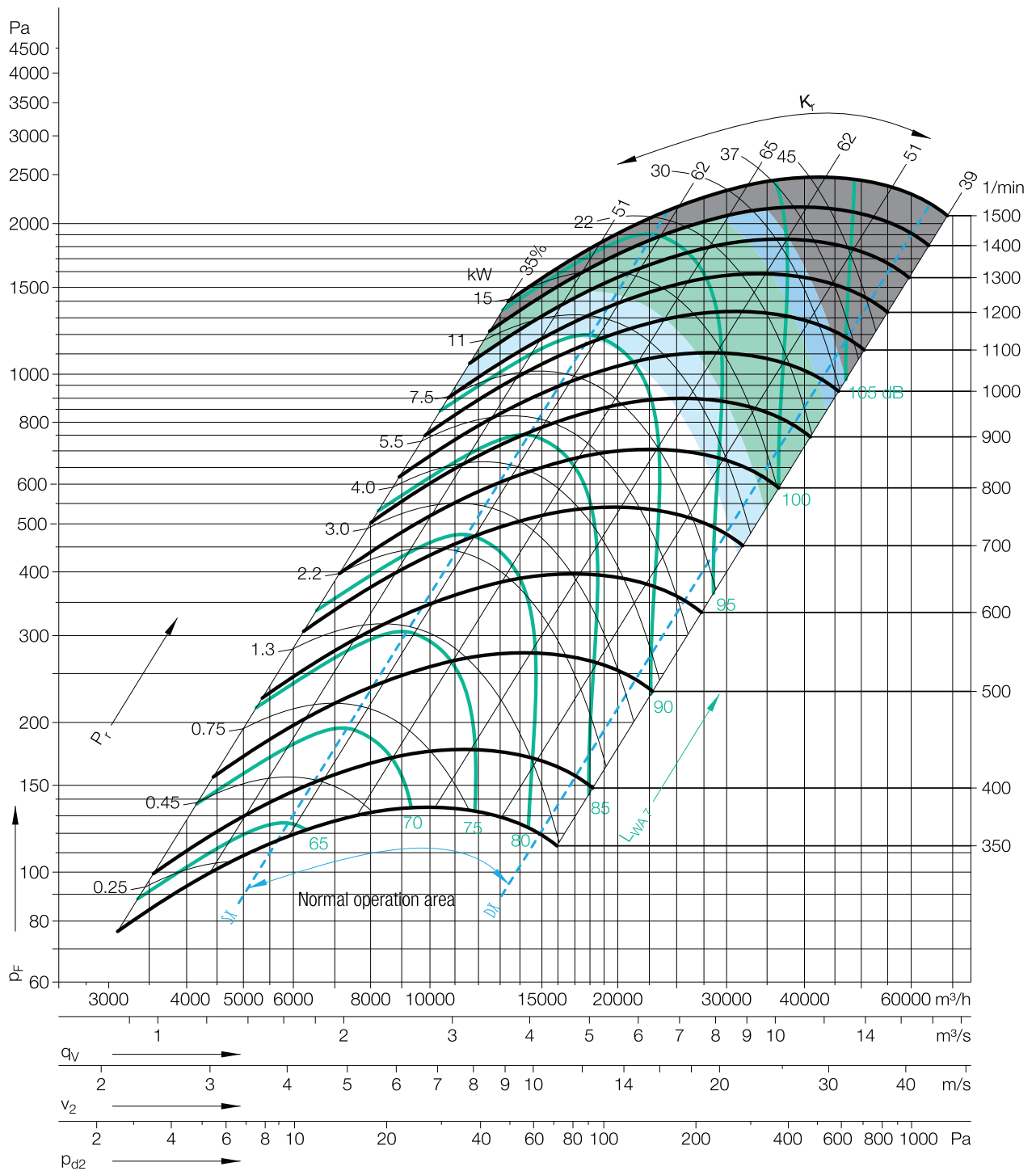

3 RADYAL FANLAR RADIAL FANS



RCAD - 560

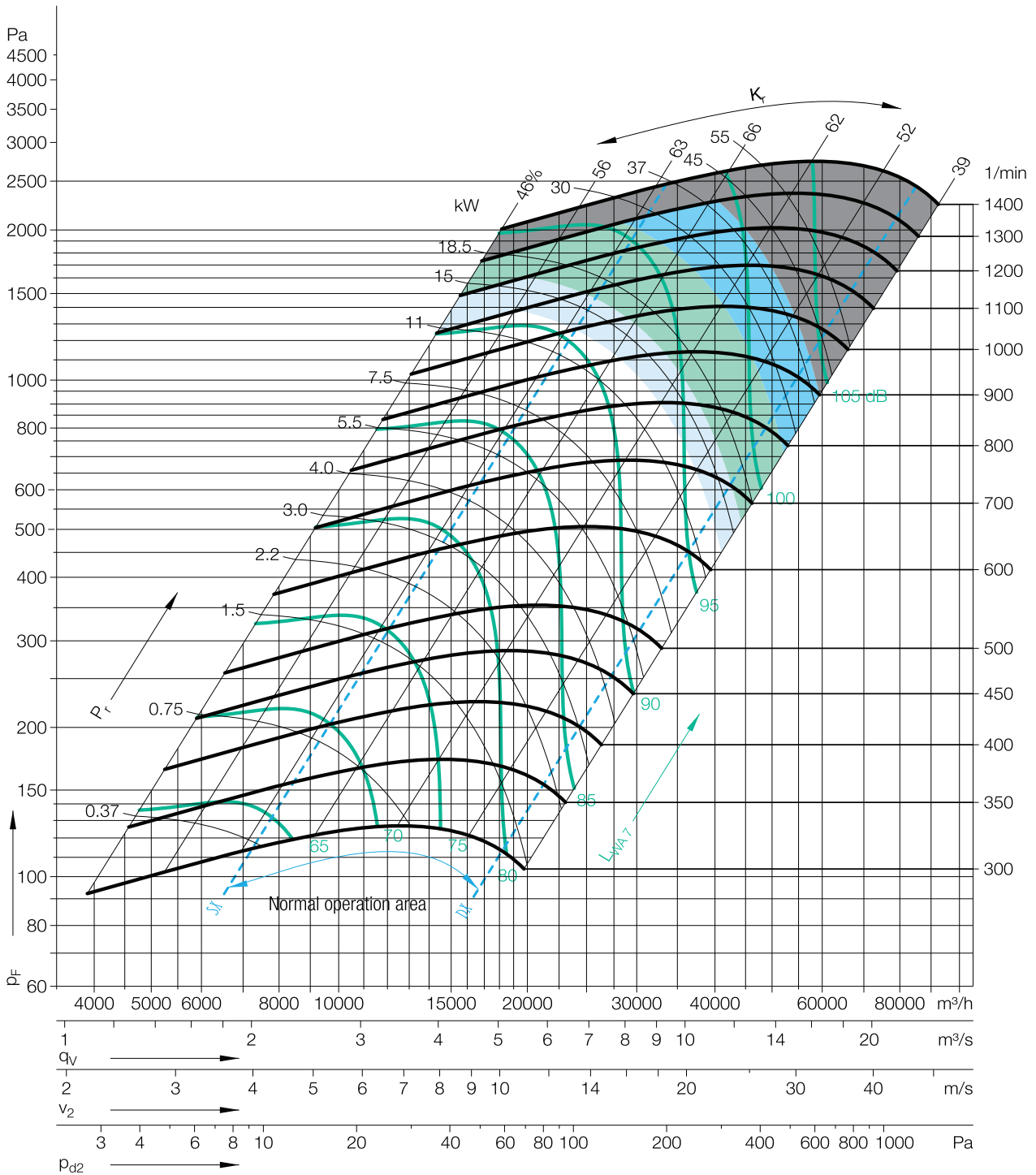



RCAD - 630

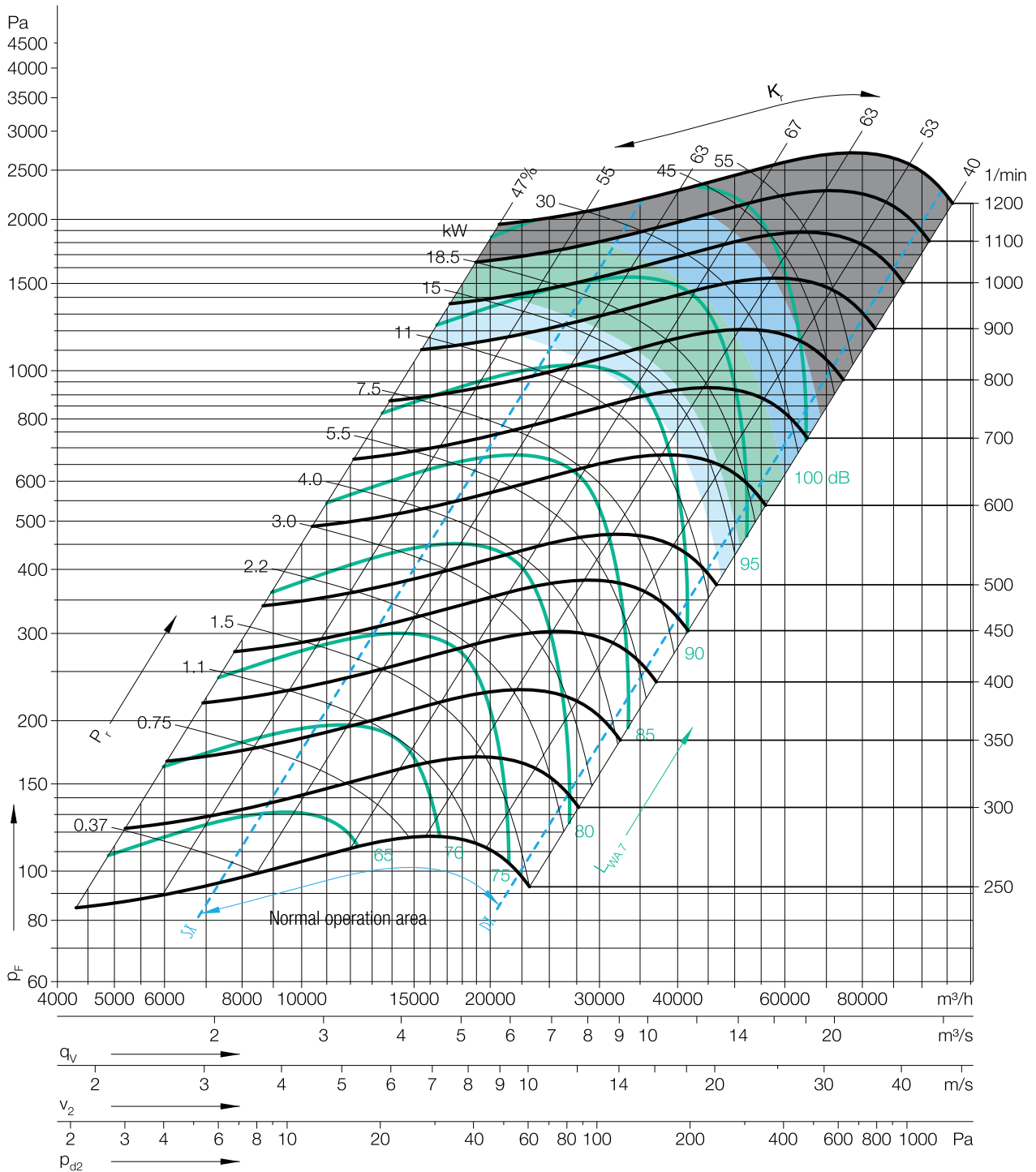

RCAD - 710

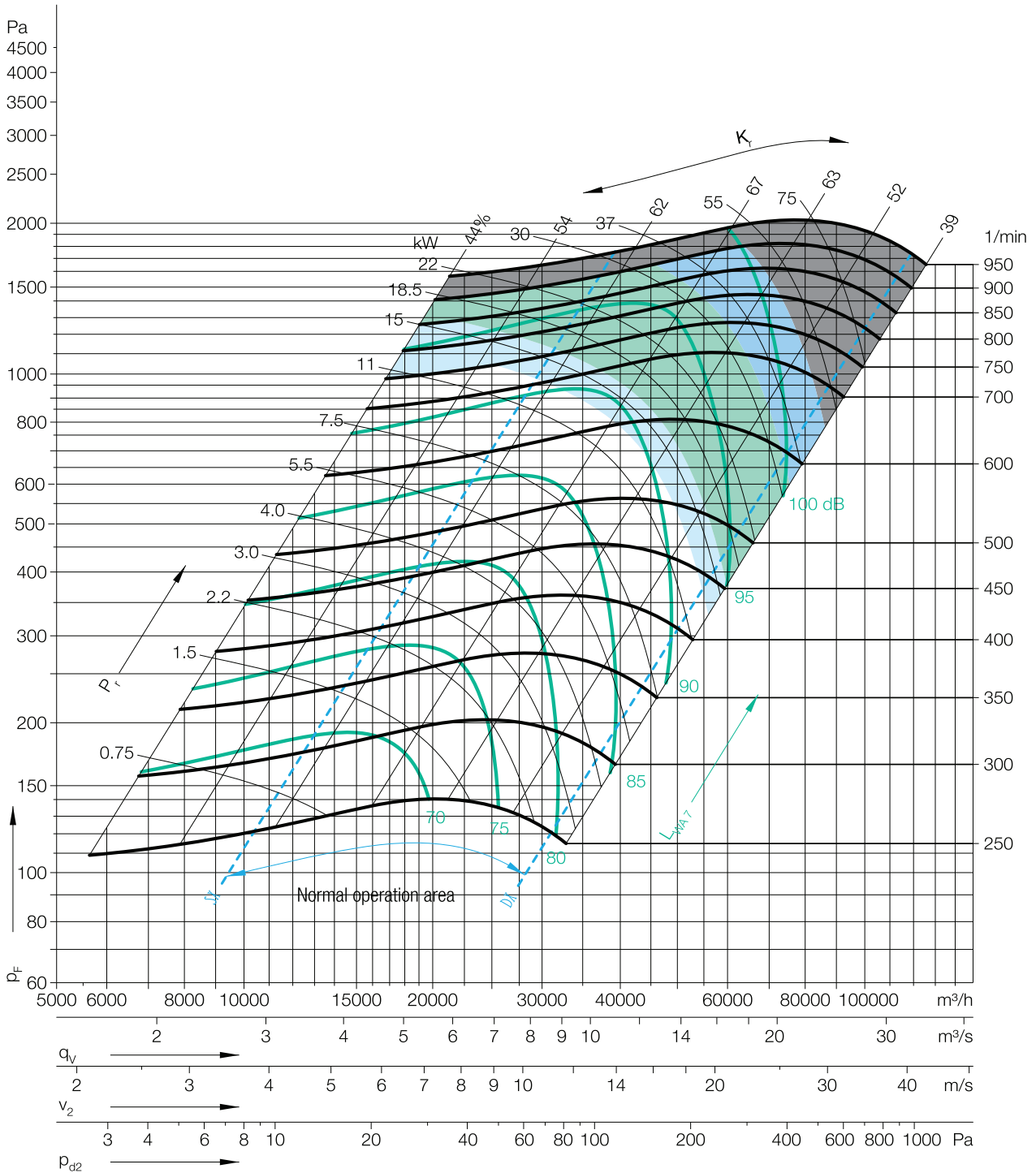

Discover the potential



RCAD - 800

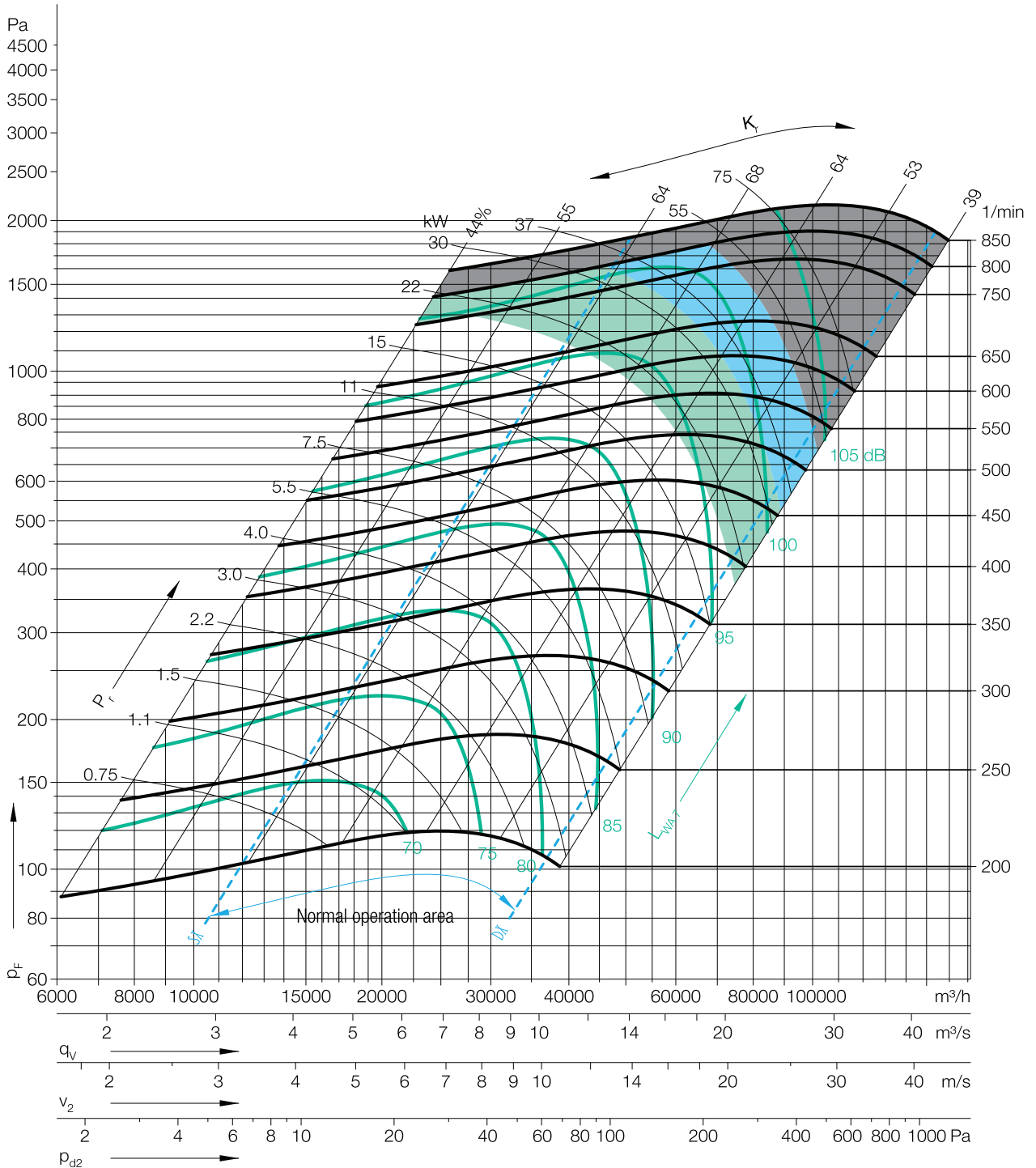

RCAD - 900

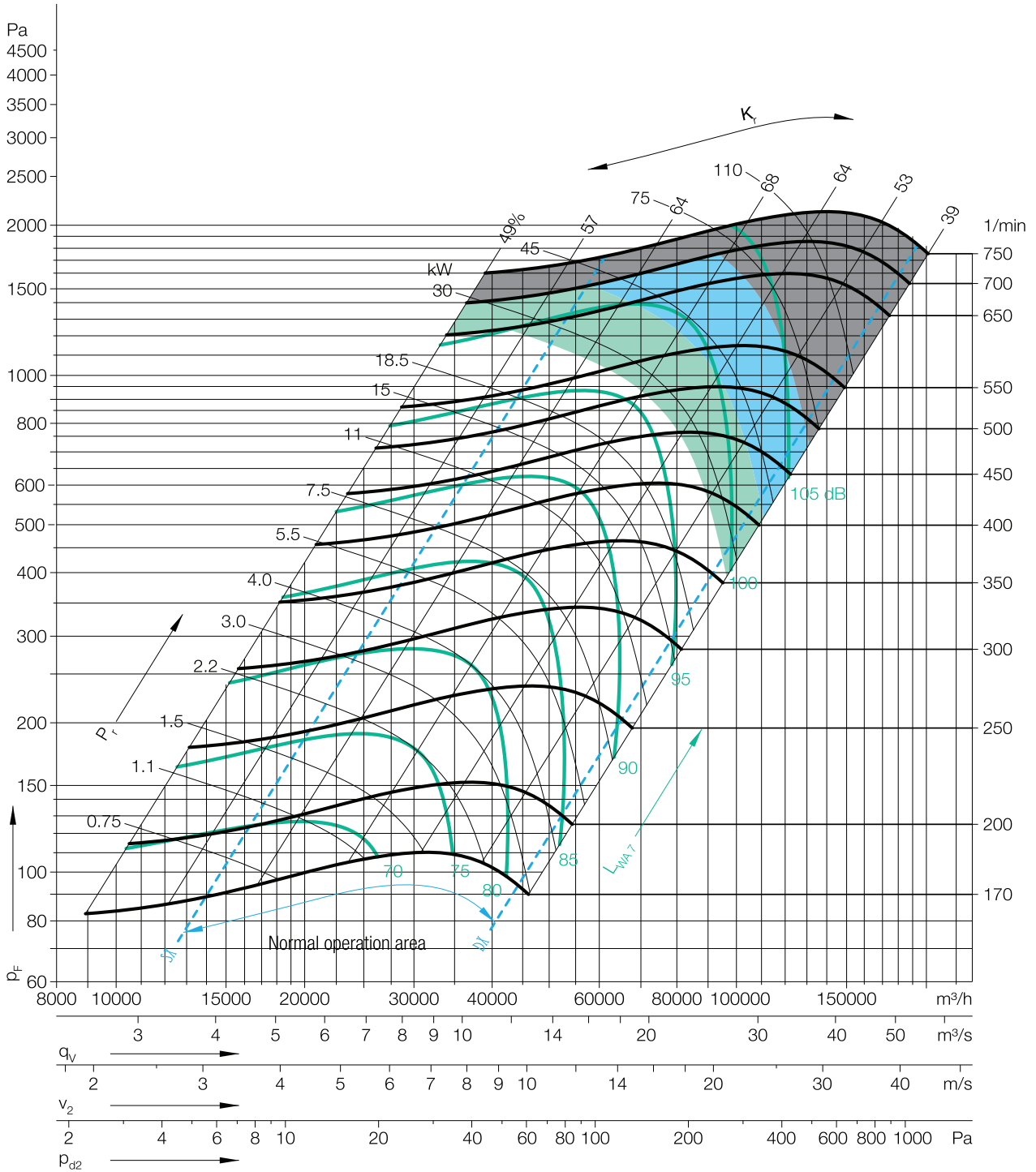

NOT _____



NOT

ACTIVENT®

Halkalı Merkez Mahallesi
Şehit Yılmaz Özdemir Caddesi
Sanayi Sokak No: 4
Küçükçekmece, İstanbul, Türkiye

P: +90.212 698 02 25

P: +90.212 698 02 26

P: +90.212 565 73 03

info@activent.com.tr

www.activent.com.tr

