

GÜÇLÜ BİR GELECEK İÇİN STRONGER FOR THE FUTURE



www.activent.com.tr



ACTIVENT®

ÜRÜN KATALOĞU
PRODUCT CATALOGUE

1 HÜCRELİ ASPİRATÖRLER CABINET FAN

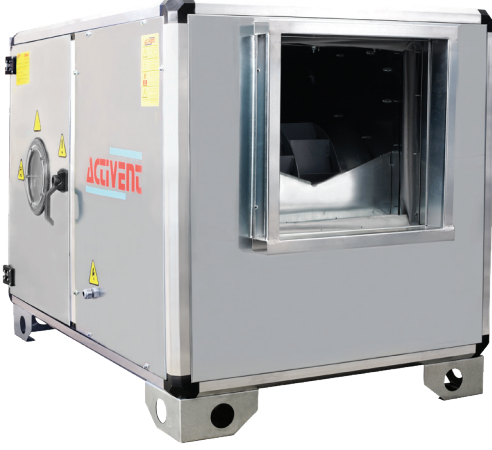

HCRD

KAYIŞ-KASNAK TAHRİK MEKANİZMALI
GERİYE EĞİMLİ ve SEYREK KANATLI
ÇİFT EMİŞLİ RADYAL FANLI, HÜCRELİ ASPİRATÖR
BELT-PULLEY DRIVE MECHANISM
DOUBLE SUCTION CABINET FANS
(BACKWARD CURVED)

HCRD çift emişli santrifüj hücreli fanlar 2.500 m³/h ile 80.000 m³/h debileri arasında değişik boyutlarda üretilmektedir. Hücre panelleri 20 mm kalınlıkta ve 70 kg/m³ yoğunlukta kaya yünü izolelidir. Titreşimsiz çalışmaya özelliğine sahip, düşük enerji ile maksimum verim sağlarlar.

HIZ KONTROLÜ

Frekans invertörü ile sağlanabilirler.

MALZEME

Gövdesi; Galvaniz sacdan üretilmiştir. 20 mm kalınlığında kaya yünü izolelidir. Alüminyum kafes yapısında imal edilirler. Radyal fan, geriye eğimli kanat yapısında St-37 DKP sacdan imal edilmiştir elektrostatik toz boyalıdır.

KULLANIM ALANLARI

İş yerleri, ofisler, fabrikalar, hastahaneler, restoranlar, toplantı salonları, süpermarketler, alışveriş merkezleri vb.

HCRD double suction centrifugal cell fans are produced in different sizes between 2.500 m³ / h and 80.000 m³/h flow rates. The cell panels are rock wool insulated with a thickness of 20 mm and a density of 70 kg/m³. Flicker free. They have the feature of working and provide maximum efficiency with low energy.

SPEED CONTROL

Frequency inverter can be used.

MATERIAL

Its body is made of galvanized sheet metal. rock wool with a thickness of 20 mm is insulated. They are manufactured in an aluminum lattice structure. Radial fan, in a backward-inclined wing structure St-37 DKP is made of sheet metal and electrostatic powder coated.

USAGE AREAS

Workplaces, offices, factories, hospitals, restaurants, meeting rooms, supermarkets, shopping malls and so on.

Tip/Kod Type/Code	Fan Tipi Fan Type	Elektrik Motoru / Electrical Motor				Max. Debi Air Flow m ³ / h	Max. Basınç Kaybı Pressure Pa
		Voltaj Voltage	Güç Power		Devir Speed		
		(V)	(HP)	(kW)	(d/d) (rpm)		
HCRD-280-2,00-T-2K	RCRD-280	380	2,00	1,50	2.880	5.500	400
HCRD-280-3,00-T-2K	RCRD-280	380	3,00	2,20	2.880	6.500	450
HCRD-315-3,00-T-2K	RCRD-315	380	3,00	2,20	2.880	7.500	450
HCRD-315-4,00-T-2K	RCRD-315	380	4,00	3,00	2.880	8.500	500
HCRD-355-4,00-T-2K	RCRD-355	380	4,00	3,00	2.880	10.000	425
HCRD-355-5,50-T-2K	RCRD-355	380	5,50	4,00	2.880	11.500	375
HCRD-400-5,50-T-2K	RCRD-400	380	5,50	4,00	2.880	13.000	400
HCRD-400-7,50-T-2K	RCRD-400	380	7,50	5,50	2.900	14.500	500
HCRD-450-7,50-T-4K	RCRD-450	380	7,50	5,50	1.465	16.000	500
HCRD-450-10,0-T-4K	RCRD-450	380	10,0	7,50	1.465	18.500	600
HCRD-500-10,0-T-4K	RCRD-500	380	10,0	7,50	1.465	21.000	500
HCRD-500-15,0-T-4K	RCRD-500	380	15,0	11,0	1.470	25.000	500

DEĞER TABLOSU / VALUE CHART (m³ / h & Pa)

Tip/Kod Type/Code	Hava Debileri (m ³ /h) / Air Flow (m ³ /h)														
	300 Pa	350 Pa	400 Pa	450 Pa	500 Pa	600 Pa	700 Pa	800 Pa	900 Pa	1000 Pa	1100 Pa	1200 Pa	1300 Pa	1400 Pa	1500 Pa
HCRD-280-2,00-T-2K	5.850	5.700	5.500	5.300	5.100	4.800	4.400	4.000	3.700						
HCRD-280-3,00-T-2K	6.900	6.700	6.600	6.500	6.300	6.000	5.700	5.300	5.000	4.700	4.400	4.000	3.700	3.200	3.000
HCRD-315-3,00-T-2K	8.100	7.900	7.700	7.500	7.200	6.800	6.300	5.800	5.400	4.900	4.500				
HCRD-315-4,00-T-2K	9.300	9.000	8.800	8.600	8.500	8.100	7.700	7.300	6.800	6.450	6.000	5.500	5.100	4.800	4.300
HCRD-355-4,00-T-2K	10.500	10.300	10.100	9.800	9.500	9.000	8.500	7.900	7.300	6.700	6.100				
HCRD-355-5,50-T-2K	11.900	11.600	11.300	11.200	11.000	10.500	10.000	9.500	9.000	8.500	8.000	7.500	6.900	6.300	5.800
HCRD-400-5,50-T-2K	13.800	13.400	13.000	12.800	12.500	11.800	11.000	10.400	9.600	9.000	8.200				
HCRD-400-7,50-T-2K	15.700	15.400	15.000	14.800	14.500	14.000	13.000	12.500	12.000	11.500	10.800	10.000	9.600	9.000	8.000
HCRD-450-7,50-T-4K	17.800	17.300	17.000	16.500	16.000	15.500	14.500	13.900	13.000	12.300	11.500	10.500			
HCRD-450-10,0-T-4K	20.000	19.500	19.200	19.000	18.800	18.500	17.500	16.800	16.000	15.400	14.500	13.800	13.000	12.000	11.500
HCRD-500-10,0-T-4K	23.000	22.500	22.000	21.500	21.000	20.600	19.500	18.700	17.600	16.800	15.800	14.800	13.700	12.500	
HCRD-500-15,0-T-4K	27.000	26.500	26.000	25.500	25.000	24.500	24.000	23.000	22.000	21.500	20.500	19.000	18.500	18.000	17.000

TEKNİK ÖLÇÜLER / TECHNICAL DIMENSION

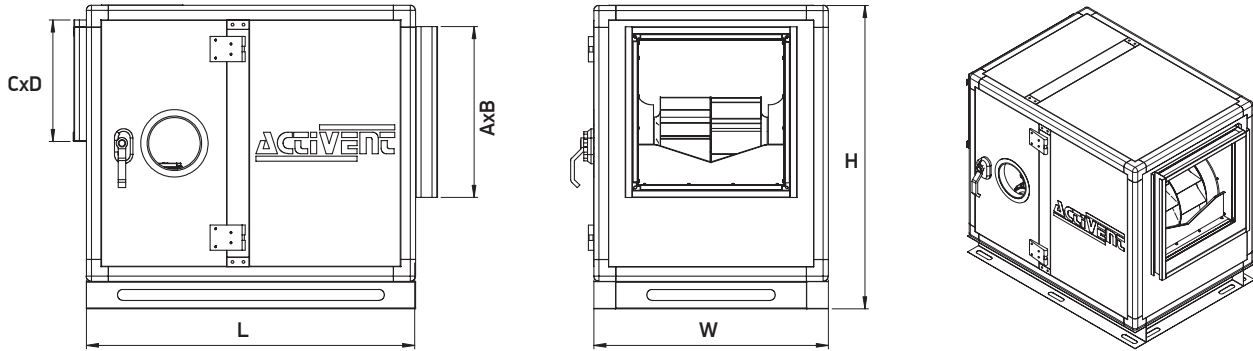

Tip/Kod Type/Code	Ölçüler / Sizes (mm)						
	L	W	H	A	B	C	D
HCRD-280	1.050	750	750	361	361	650	350
HCRD-315	1.100	850	850	404	404	750	400
HCRD-355	1.200	900	900	453	453	800	500
HCRD-400	1.240	1.000	1.000	507	507	900	550
HCRD-450	1.400	1.100	1.100	569	569	1.000	600
HCRD-500	1.600	1.200	1.200	638	638	1.100	650

1 HÜCRELİ ASPIRATÖRLER CABINET FAN



HÜCRELİ FAN EMİŞ - ATIŞ YÖNLERİ / CELL FUN SUCTION - BLOWING ASPECTS

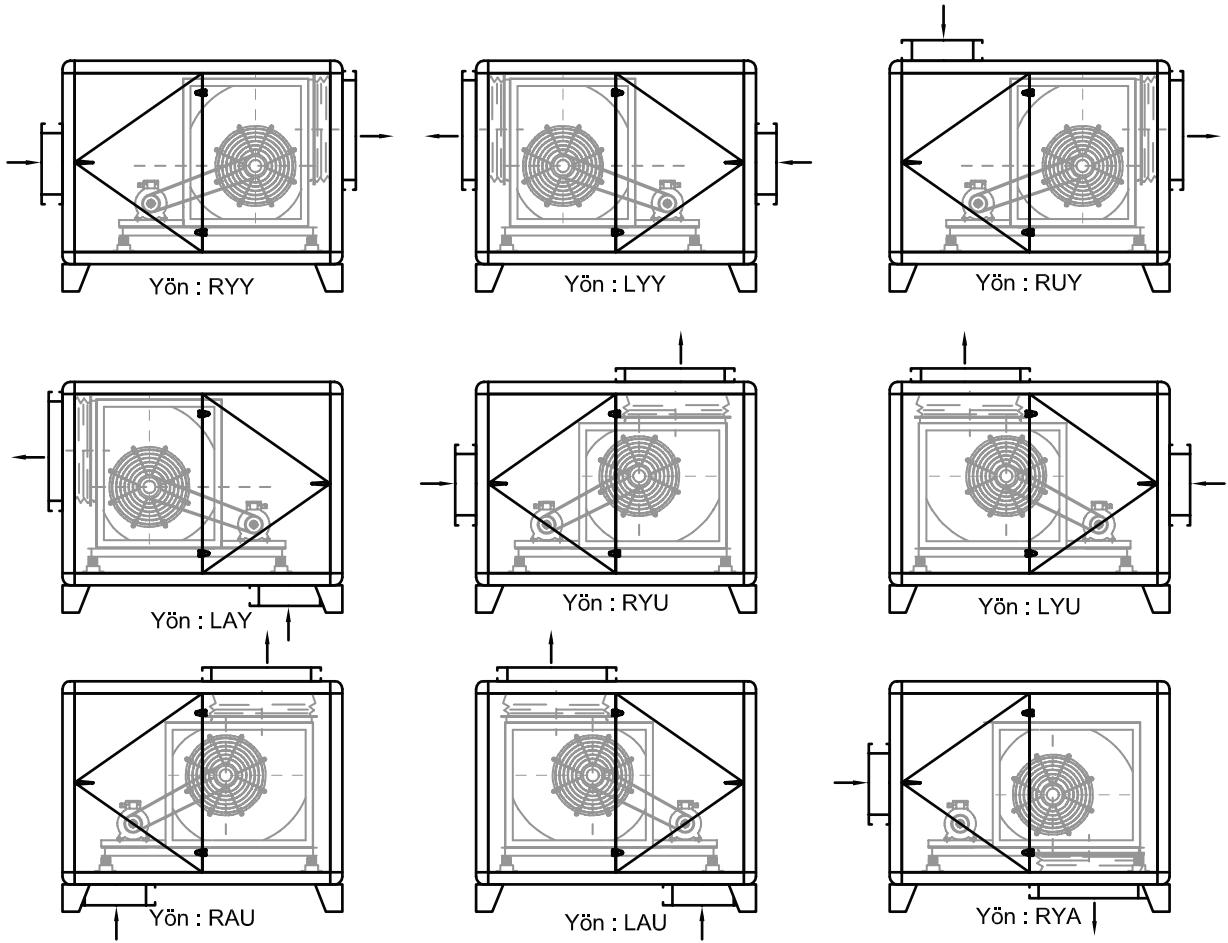

Discover the potential



ACTIVENT
"Fan Motors & Ventilation Systems"

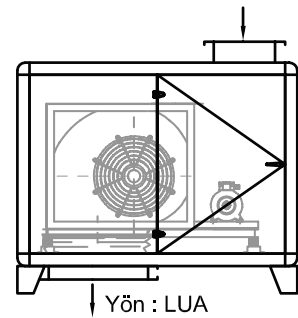
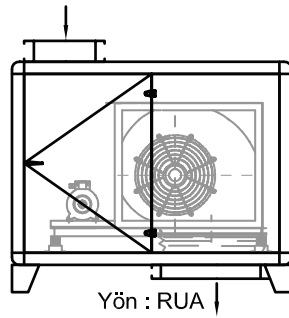
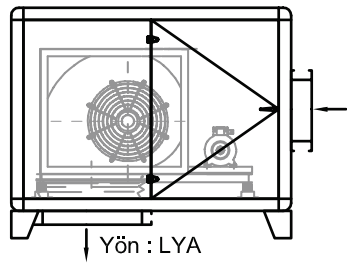
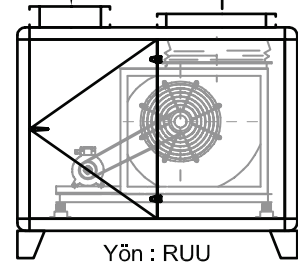
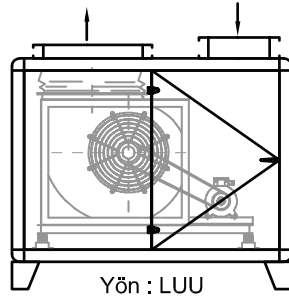
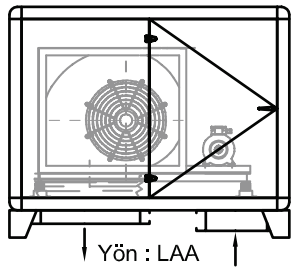
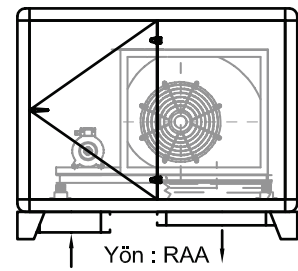
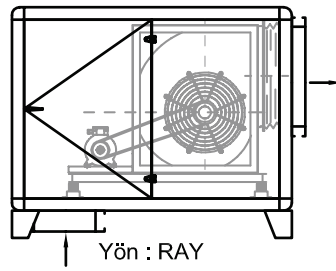
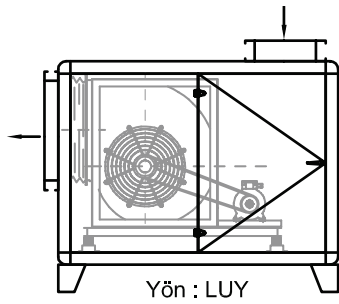

1 HÜCRELİ ASPİRATÖRLER CABINET FAN



HCRD - 280

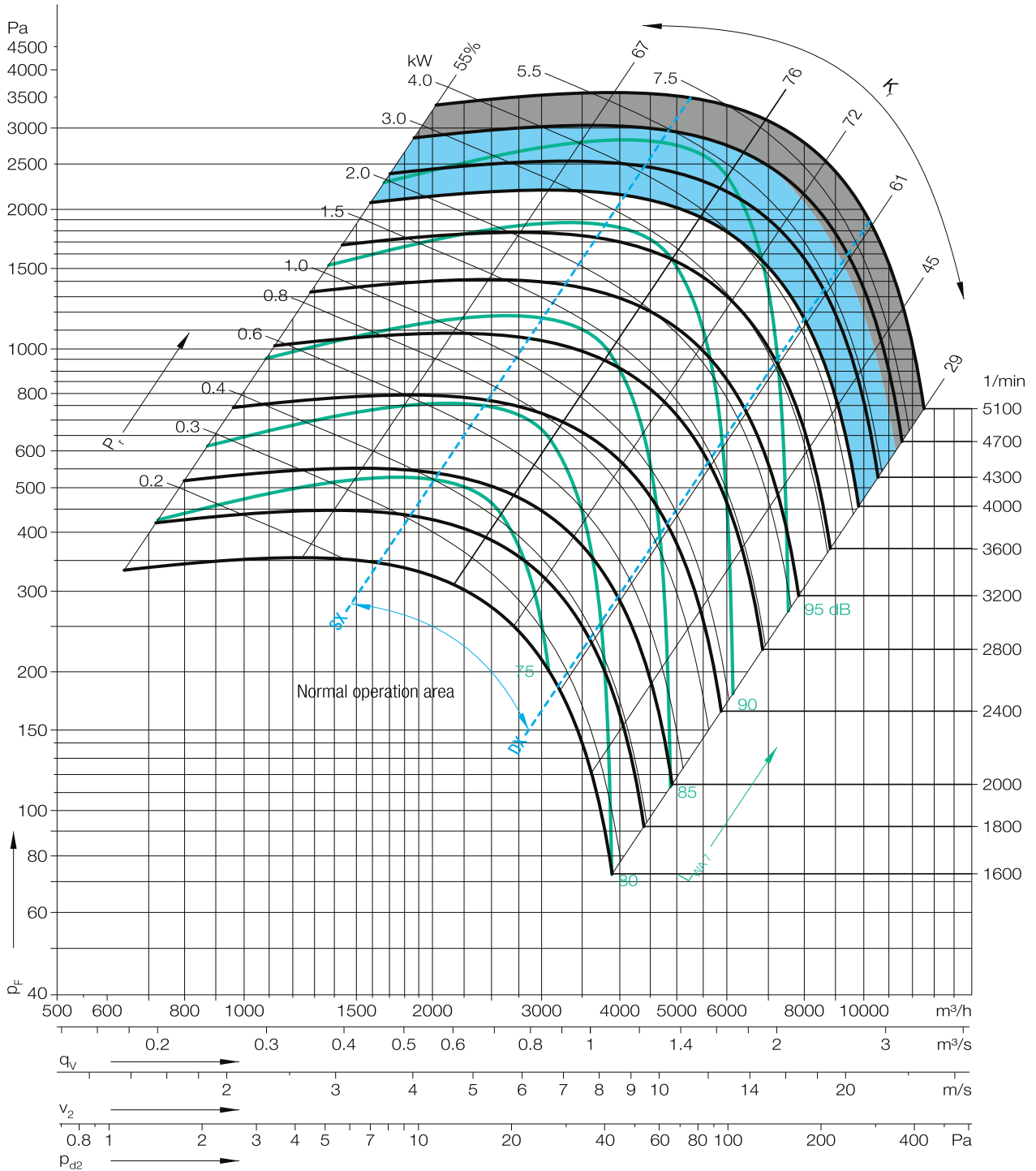



HCRD - 315

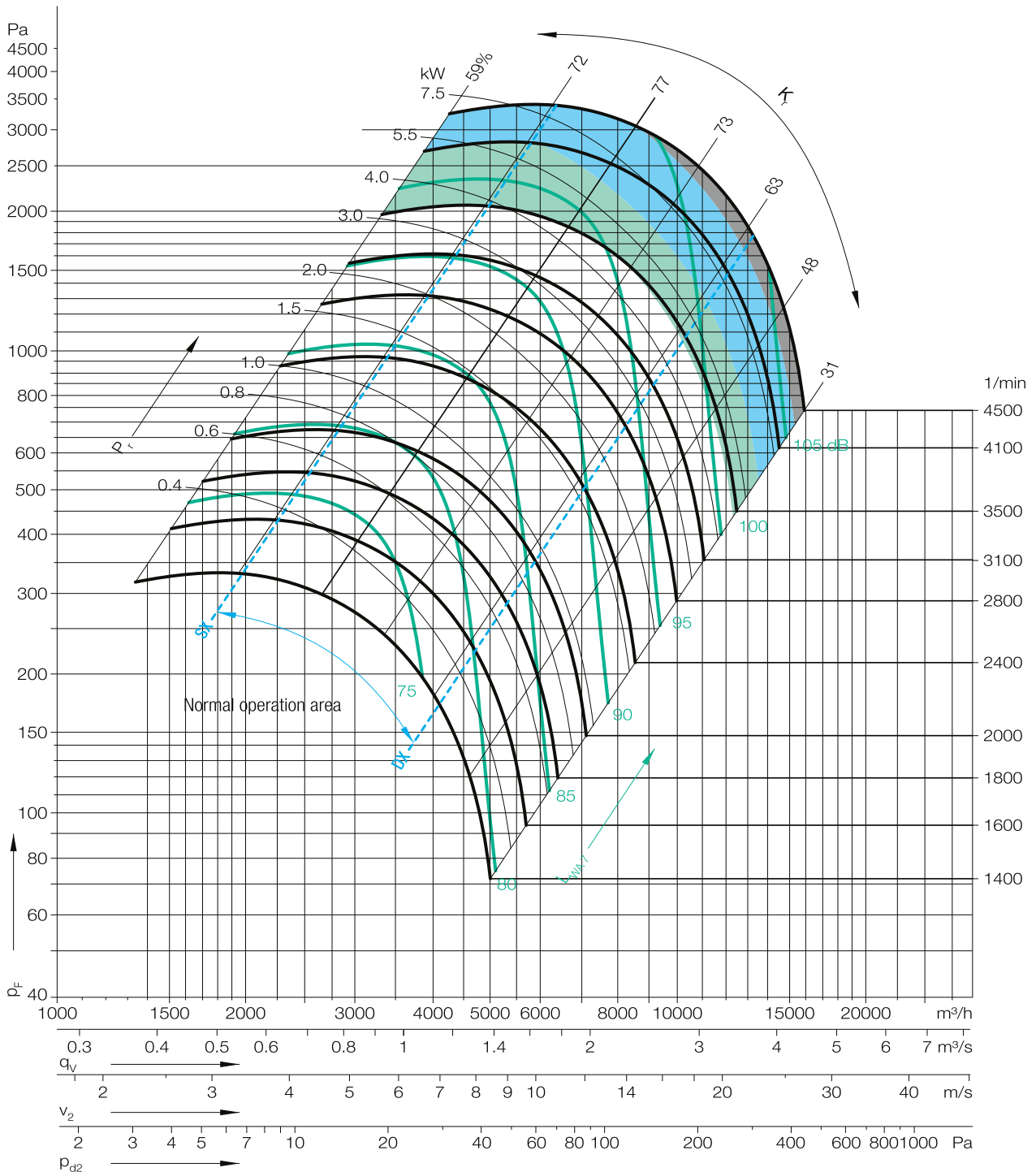

1 HÜCRELİ ASPİRATÖRLER CABINET FAN

HCRD - 355

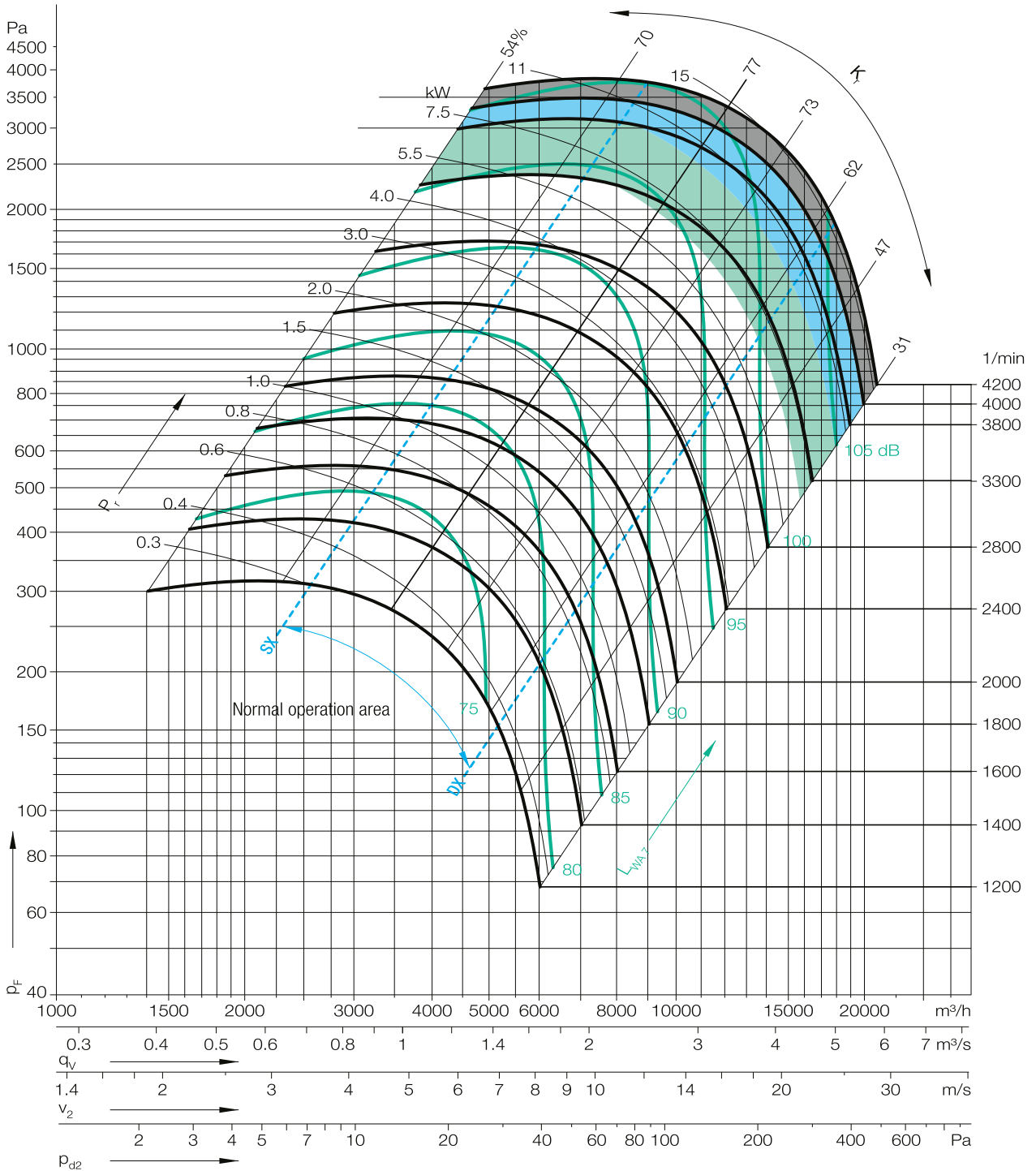



HCRD - 400

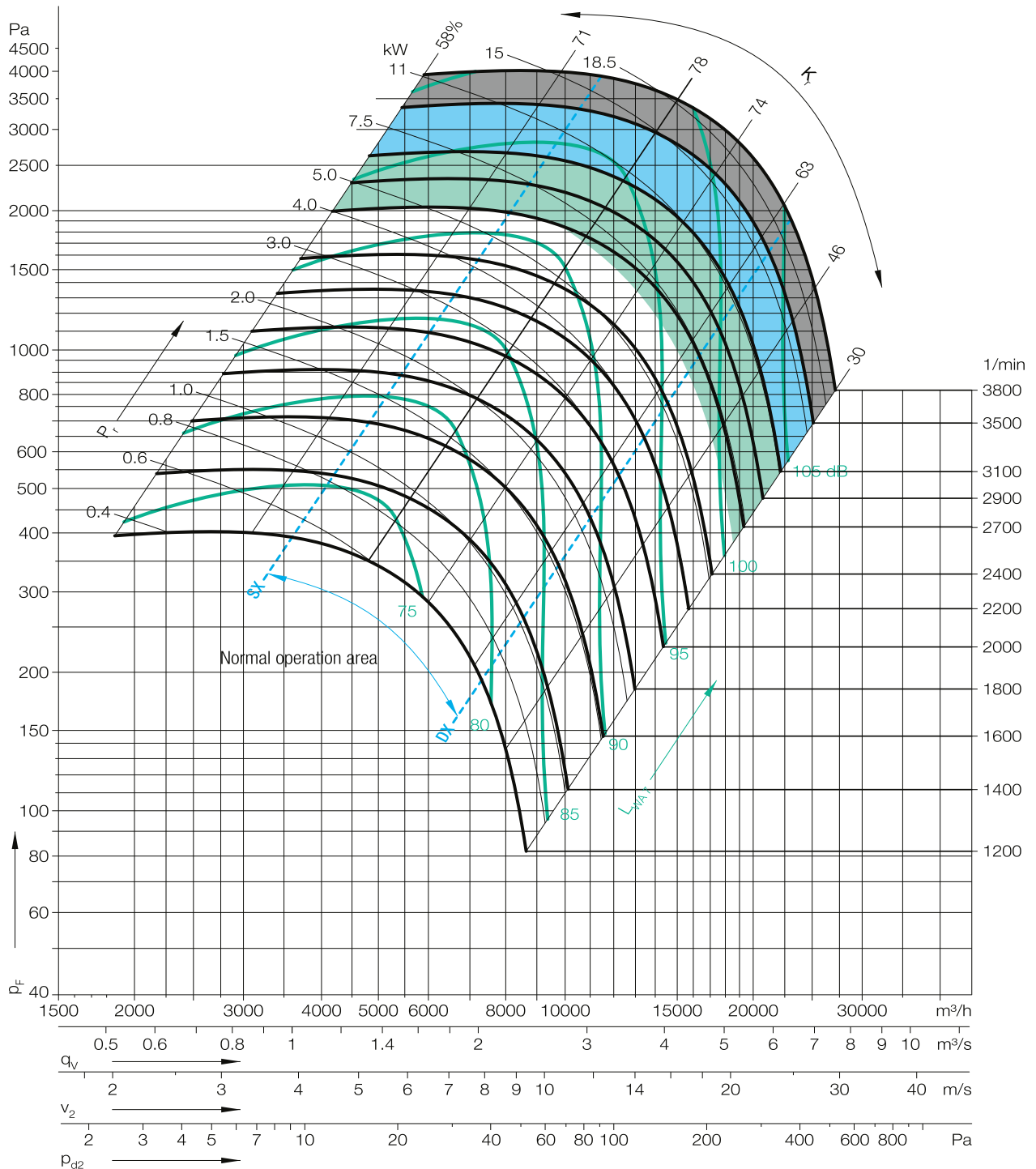

1 HÜCRELİ ASPİRATÖRLER CABINET FAN

HCRD - 450

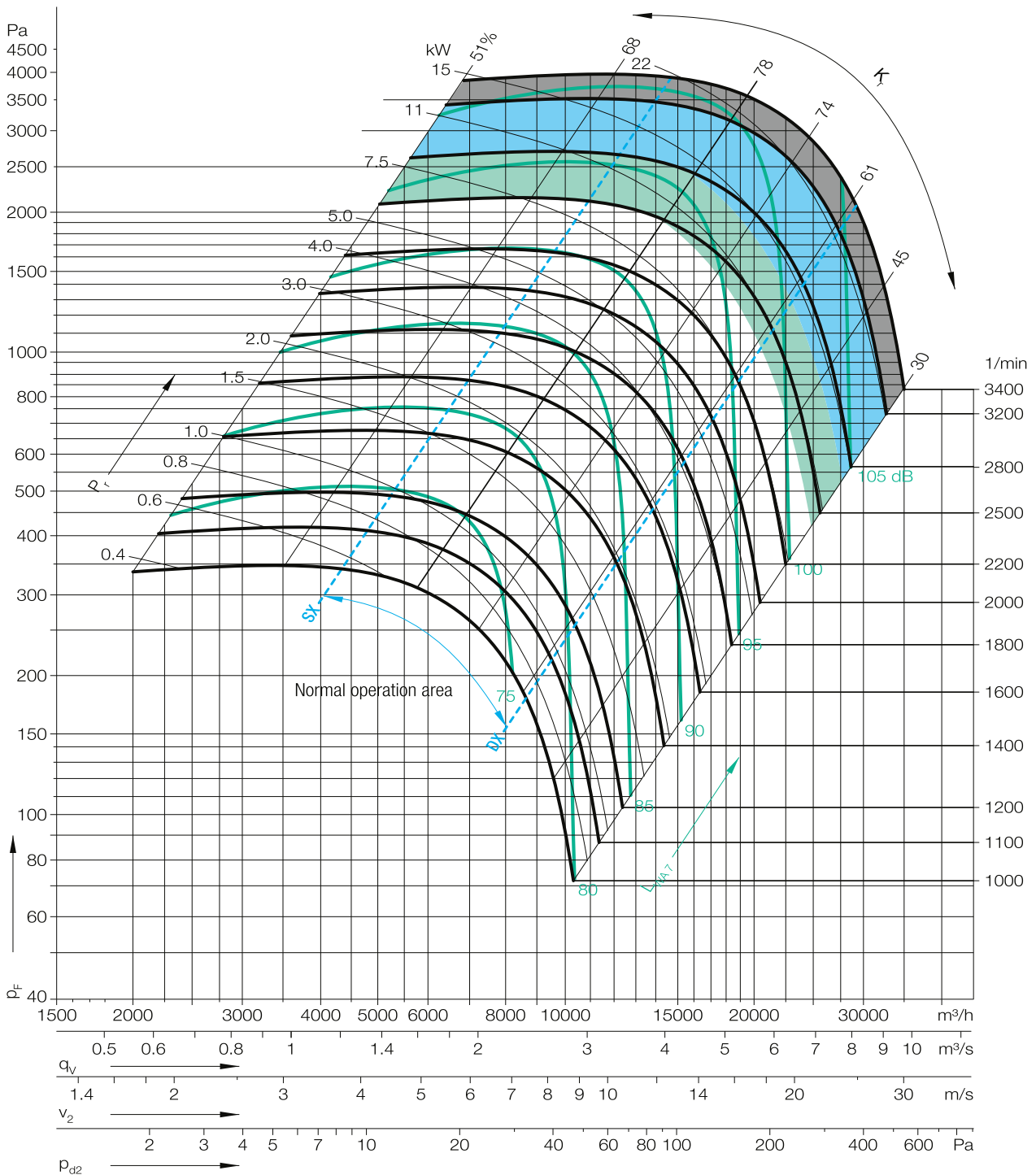



HCRD - 500

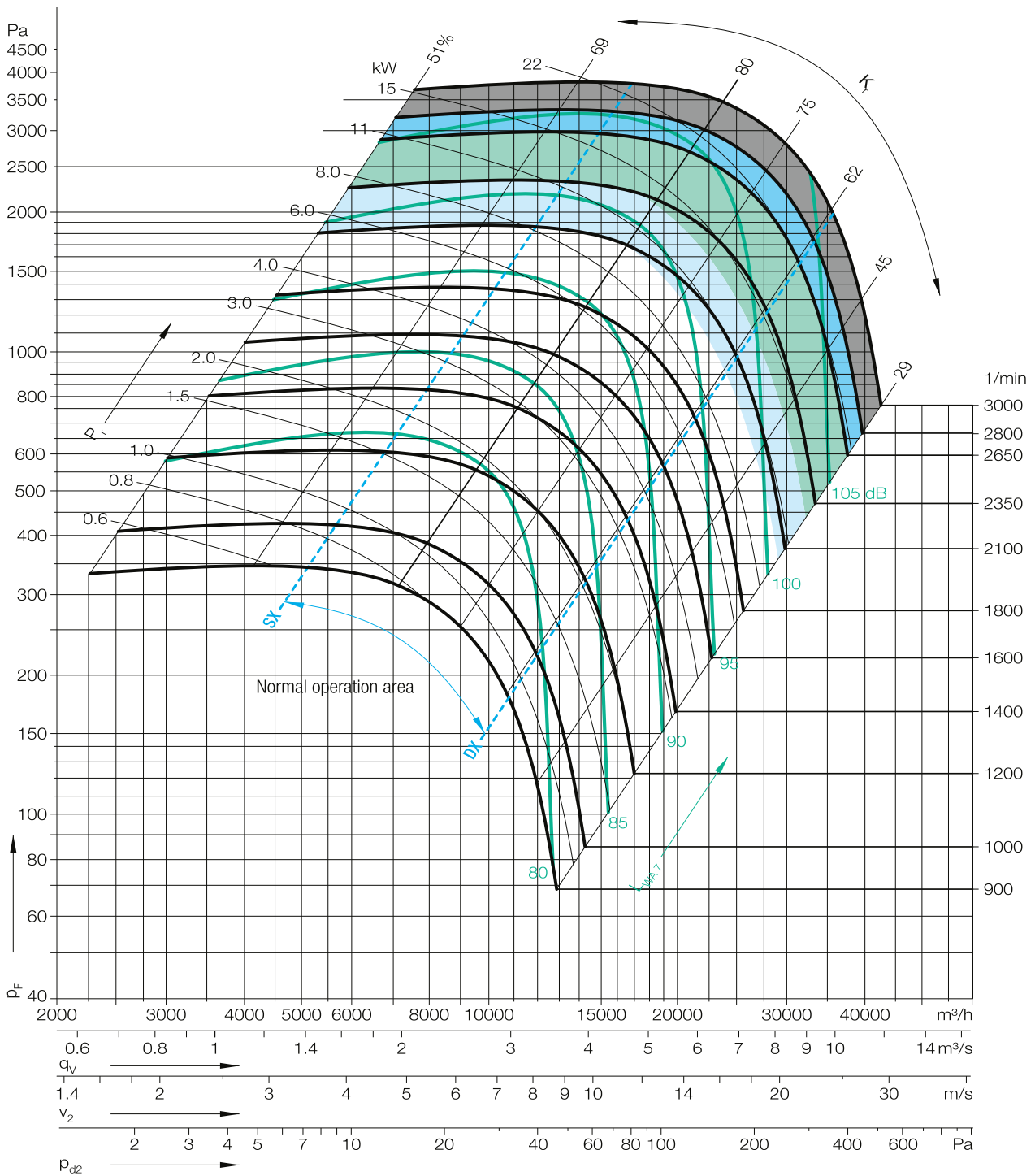

ACTIVENT®

Halkalı Merkez Mahallesi
Şehit Yılmaz Özdemir Caddesi
Sanayi Sokak No: 4
Küçükçekmece, İstanbul, Türkiye

P: +90.212 698 02 25

P: +90.212 698 02 26

P: +90.212 565 73 03

info@activent.com.tr

www.activent.com.tr

