

GÜÇLÜ BİR GELECEK İÇİN STRONGER FOR THE FUTURE



www.activent.com.tr



ACTIVENT®

ÜRÜN KATALOĞU
PRODUCT CATALOGUE



ASTD

6 KANATLI METAL PERVENELİ
DİREKT AKUPLE MOTORLU
KARE KASALI, SANAYİ TİPİ

6 WING METAL PROPELLER
SQUARE FRAME INDUSTRIAL TYPE
ASPIRATOR

ASTD duvar ve pencereye montaj imkanı olan bu fanlar güçlü hava akımı sağlarlar. Düşük ses seviyeleri ve yüksek verimleri ile ekonomik fanlardır.

MALZEME

Gövdesi ve pervanesi elektrostatik toz boyalı sacdan mamuldür.

HIZ KONTROLÜ

Opsiyonel olarak hız anahtarı ile sağlanabilir.

KULLANIM ALANLARI

Fabrikalar, depolar, boyahaneler, alışveriş merkezleri, imalathaneler vb. büyük hacimli yerlerin havalandırılması için kullanılır.

ASTD these fans which can be mounted on the walls and windows provide a strong air flow. They are economic fans with low sound levels and a high productivity.

MATERIAL

Its body and fan are made of electrostatic powder-coated steel plate.

SPEED CONTROL

It can be supplied optionally with speed switch.

USAGE AREAS

It is used for the ventilation of large volume locations like factories, warehouses, paint shops, malls, workshops, etc.

Tip/Kod Type/Code	Elektrik Motoru / Electrical Motor			Max. Debi Air Flow (m ³ / h)
	Voltaj Voltage	Güç Power	Devir Speed	
	(V)	(W)	(d/d) (rpm)	
ASTD-250-M-4K / ASTD-250-T-4K	220 / 380	120 / 110	1.400	1.400
ASTD-250-M-2K / ASTD-250-T-2K	220 / 380	180 / 165	2.800	2.200
ASTD-300-M-4K / ASTD-300-T-4K	220 / 380	130 / 125	1.400	3.350
ASTD-350-M-4K / ASTD-350-T-4K	220 / 380	160 / 140	1.400	4.550
ASTD-400-M-4K / ASTD-400-T-4K	220 / 380	200 / 180	1.400	5.300
ASTD-450-M-4K / ASTD-450-T-4K	220 / 380	220 / 210	1.400	6.900
ASTD-500-M-4K / ASTD-500-T-4K	220 / 380	230 / 220	1.400	7.200
ASTD-600-M-4K / ASTD-600-T-4K	220 / 380	560 / 450	1.400	8.500

TEKNİK ÖLÇÜLER / TECHNICAL DIMENSION

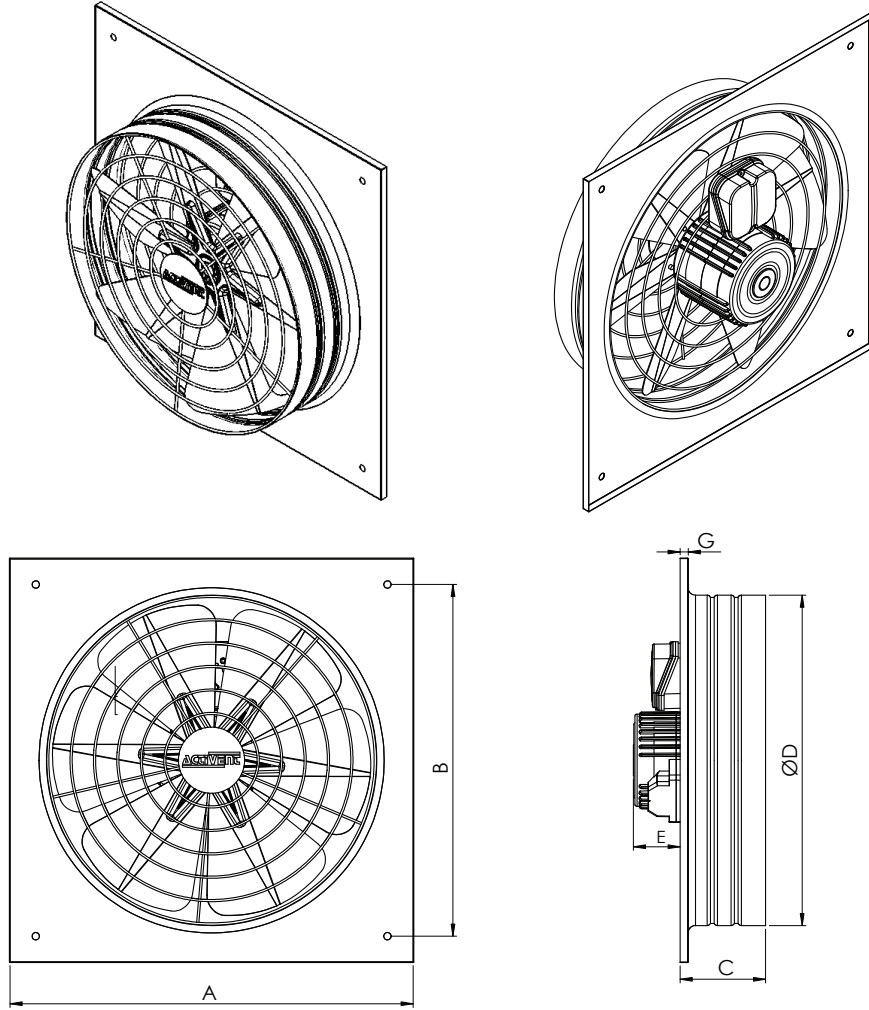

Tip/Kod Type/Code	Ölçüler / Sizes (mm)		
	AxB	D	L
ASTD-250-M-4K / ASTD-250-T-4K	350	261	80
ASTD-250-M-2K / ASTD-250-T-2K	350	261	80
ASTD-300-M-4K / ASTD-300-T-4K	400	307	80
ASTD-350-M-4K / ASTD-350-T-4K	450	365	90
ASTD-400-M-4K / ASTD-400-T-4K	500	403	100
ASTD-450-M-4K / ASTD-450-T-4K	550	462	105
ASTD-500-M-4K / ASTD-500-T-4K	600	513	110
ASTD-600-M-4K / ASTD-600-T-4K	720	612	145

TEKNİK ÖLÇÜLER / TECHNICAL DIMENSION

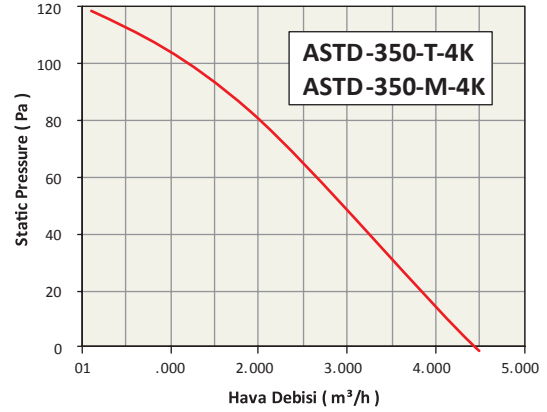
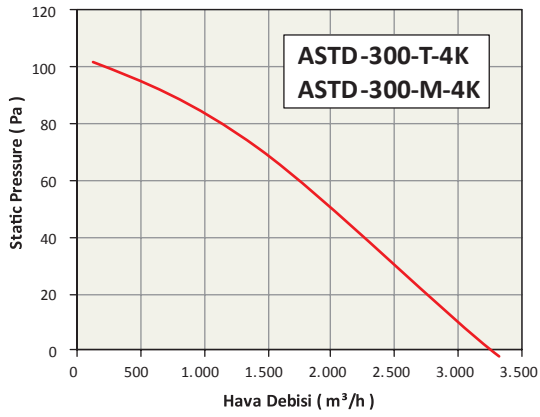
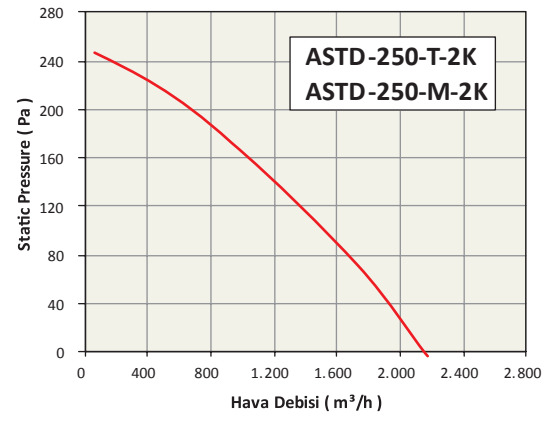
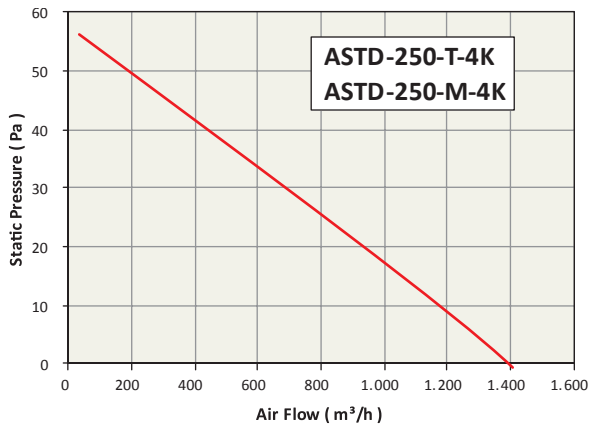

TEKNİK ÖLÇÜLER / TECHNICAL DIMENSION

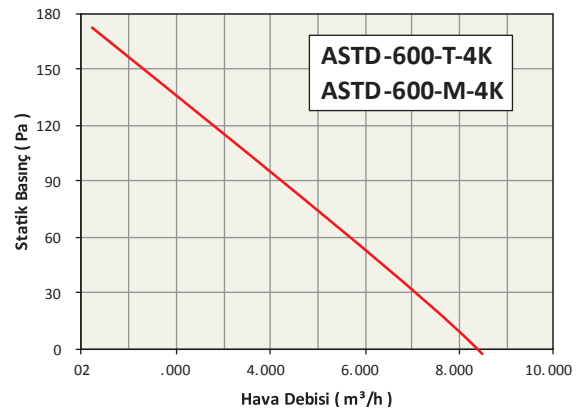
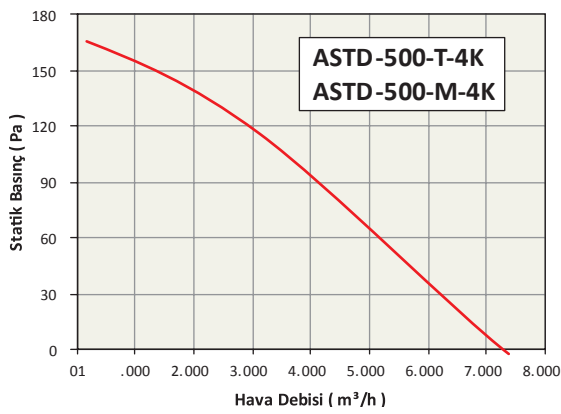
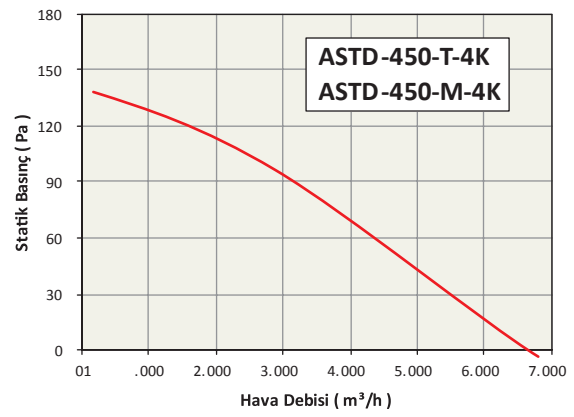
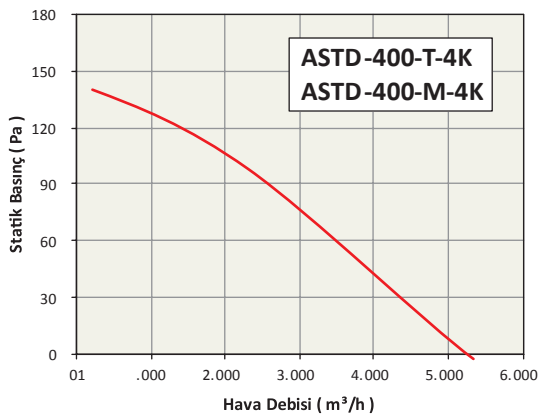

ACTIVENT®

Halkalı Merkez Mahallesi
Şehit Yılmaz Özdemir Caddesi
Sanayi Sokak No: 4
Küçükçekmece, İstanbul, Türkiye

P: +90.212 698 02 25

P: +90.212 698 02 26

P: +90.212 565 73 03

info@activent.com.tr

www.activent.com.tr

