

# GÜÇLÜ BİR GELECEK İÇİN STRONGER FOR THE FUTURE



[www.activent.com.tr](http://www.activent.com.tr)



## ACTIVENT®

ÜRÜN KATALOĞU  
PRODUCT CATALOGUE

# 4 AKSİYAL FANLAR AXIAL FANS



## AKMP

4 KANATLI METAL PERVANELİ,  
DİREKT AKUPLE MOTORLU, KOVANLI

4 WINGED METAL AXIAL FAN

**AKMP** yüksek hava debileri sağlayan bu fanlar metal pervanelere sahiptirler. Talebe göre yüksek sıcaklıklara mukavim olarak üretilebilirler.

### MALZEME

Gövdesi ve pervanesi standart olarak ST-37 sacdan elektrostatik boyalı imal edilir. İsteğe göre ayaklı olarak da üretilir.

### HIZ KONTROLÜ

Opsiyonel olarak frekans inverteri ile sağlanabilir.

### KULLANIM ALANLARI

Kanal uygulamalarında hat ortası ve sonunda tercih edilmekle beraber, teknik, endüstriyel ve dökümhanelerde ve çimento, kağıt, kereste fabrikalarında, soğutma kulelerinde vb. yerlerde kullanılabilir.

**AKMP** these fans that provide high air flows have metal fans. Upon request, they can be produced to resist high temperatures.

### MATERIAL

The body and fan are produced with electrostatic paint of ST-37 steel plate as a standard. As per request, it can also be made with a stand.

### SPEED CONTROL

It can be supplied with optional frequency inverters.

### USAGE AREAS

They are preferred in the center and end of the line for channel applications, and can also be used in technical, industrial locations and locations like foundries, cement plants, paper mills, saw mills, cooling towers, etc.

Tıp/Kod Type/Code	Elektrik Motoru / Electrical Motor			Max. Debi Air Flow (m <sup>3</sup> / h)	
	Voltaj Voltage	Güç Power	Devir Speed		
	(V)	(HP)	(kW)		(d/d) (rpm)
AKMP-300-0,50-T-4K	380	0,50	0,37	1.380	3.500
AKMP-350-0,50-T-4K	380	0,50	0,37	1.380	4.000
AKMP-400-0,50-T-4K	380	0,50	0,37	1.380	5.000
AKMP-450-0,50-T-4K	380	0,50	0,37	1.380	6.000
AKMP-500-1,00-T-4K	380	1,00	0,75	1.410	8.000
AKMP-560-1,00-T-4K	380	1,00	0,75	1.410	10.000
AKMP-630-2,00-T-4K	380	2,00	1,50	1.430	14.000
AKMP-710-3,00-T-4K	380	3,00	2,20	1.435	16.000
AKMP-800-5,50-T-4K	380	5,50	4,00	1.455	25.000
AKMP-900-7,50-T-4K	380	7,50	5,50	1.465	35.000
AKMP-1000-7,50-T-6K	380	7,50	5,50	960	40.000
AKMP-1100-7,50-T-6K	380	7,50	5,50	960	45.000
AKMP-1200-10,0-T-6K	380	10,0	7,50	960	50.000

TEKNİK ÖLÇÜLER / TECHNICAL DIMENSION

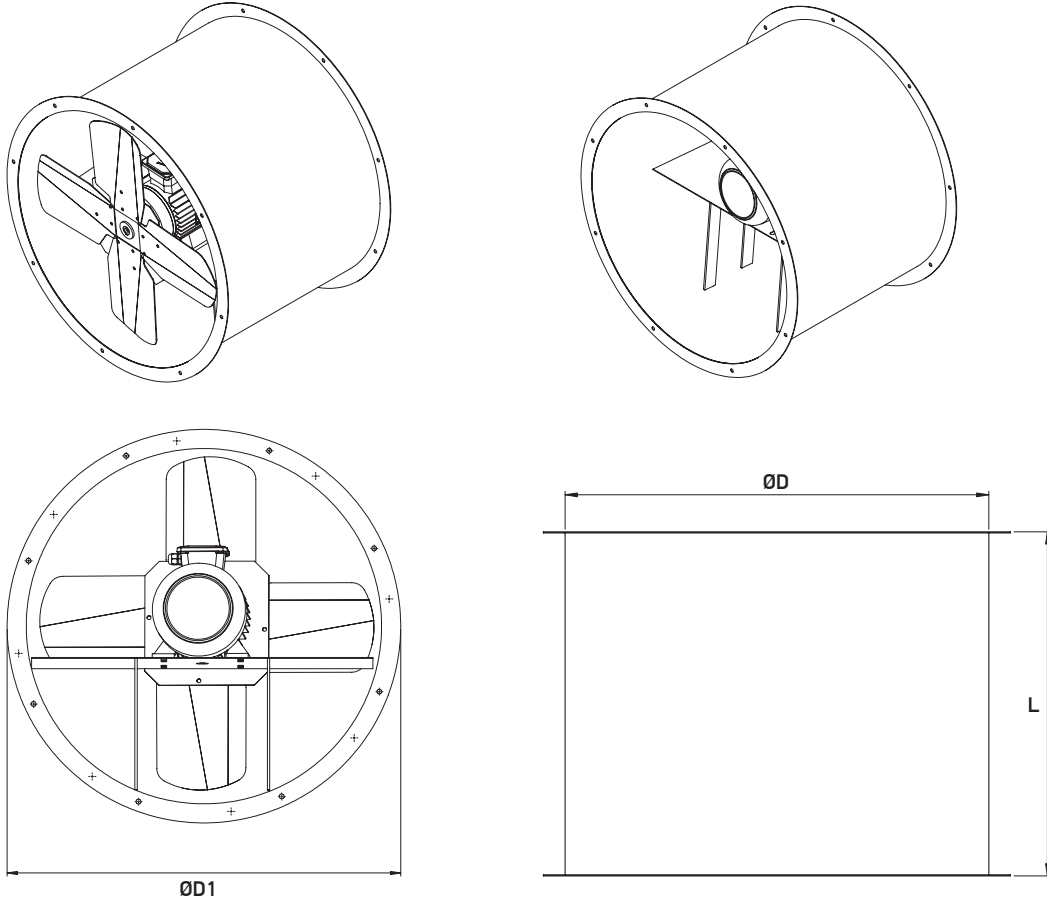

Tip/Kod Type/Code	Ölçüler / Sizes (mm)		
	ØD	ØD1	L
AKMP-300-0,50-T-4K	300	370	300
AKMP-350-0,50-T-4K	350	420	325
AKMP-400-0,50-T-4K	400	470	350
AKMP-450-0,50-T-4K	450	520	400
AKMP-500-1,00-T-4K	500	570	400
AKMP-560-1,00-T-4K	560	630	450
AKMP-630-2,00-T-4K	630	700	475
AKMP-710-3,00-T-4K	710	780	525
AKMP-800-5,50-T-4K	800	870	550
AKMP-900-7,50-T-4K	900	970	600
AKMP-1000-7,50-T-6K	1.000	1.100	600
AKMP-1100-7,50-T-6K	1.100	1.200	700
AKMP-1200-10,0-T-6K	1.200	1.300	750

## TEKNİK ÖLÇÜLER / TECHNICAL DIMENSION

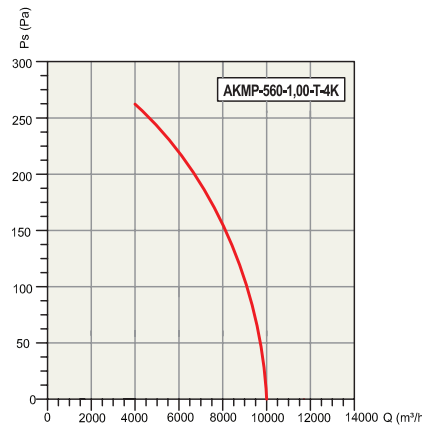
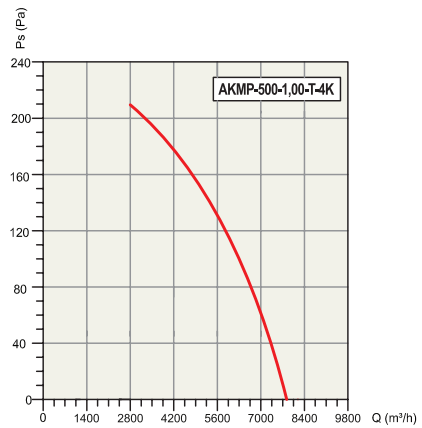
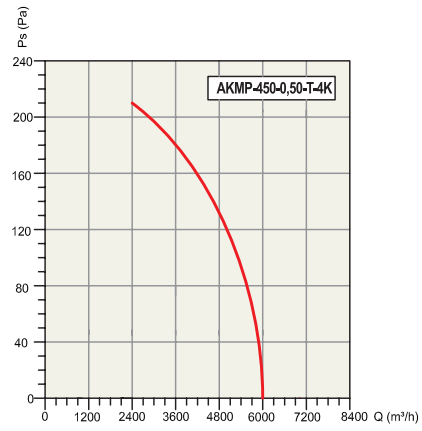
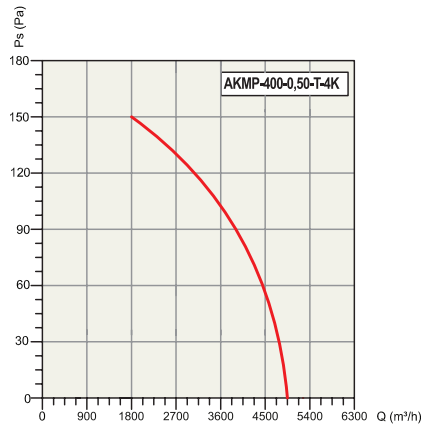
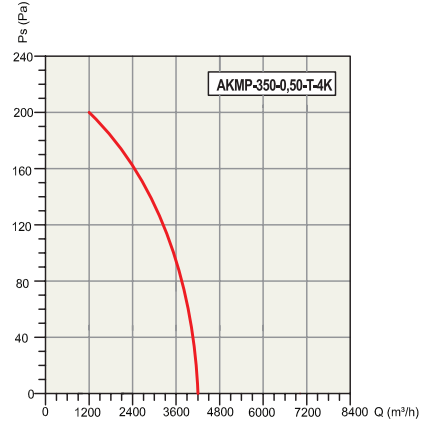
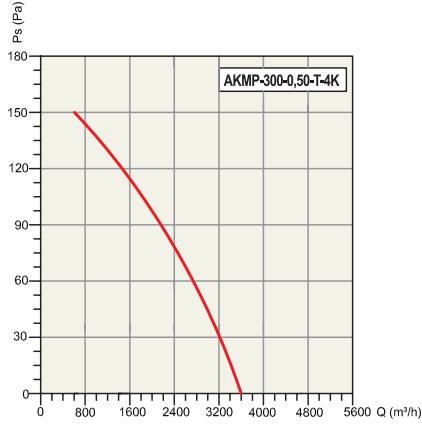

Discover the potential

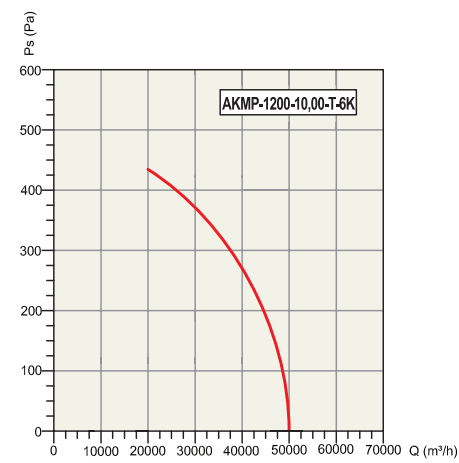
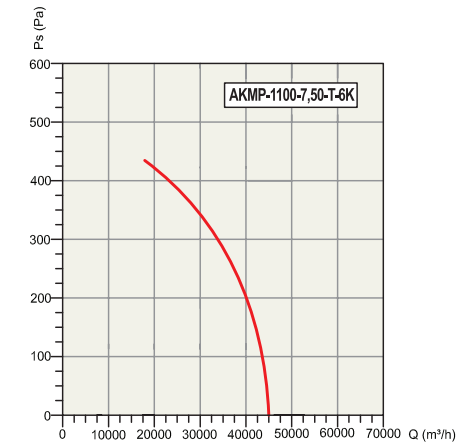
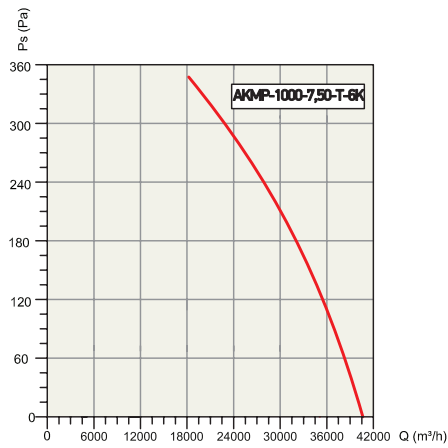
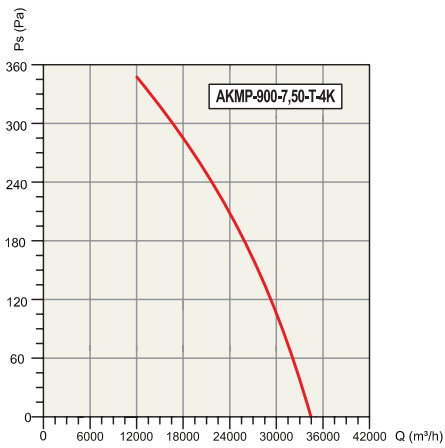
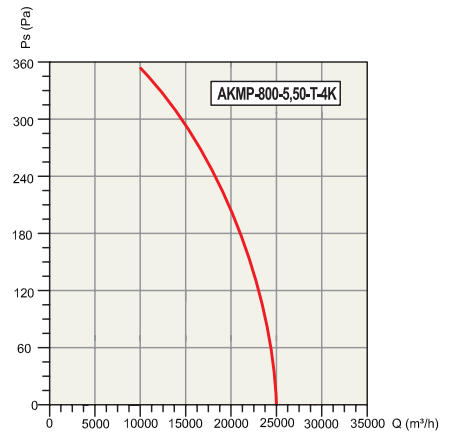
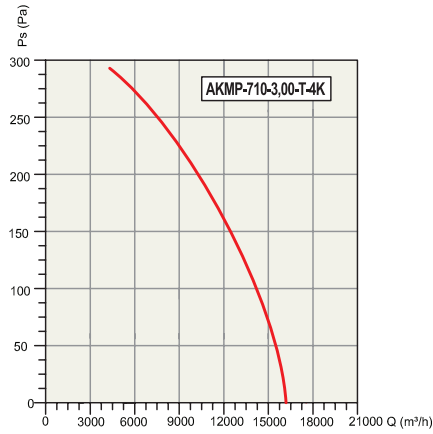
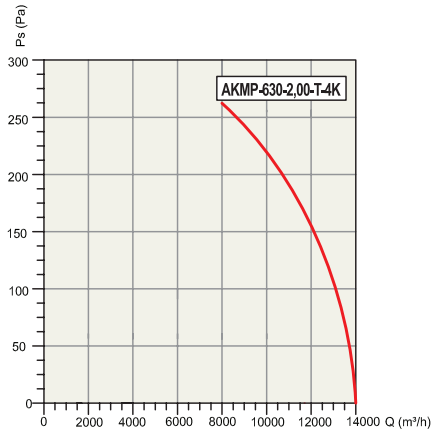





**ACTIVENT®**

Halkalı Merkez Mahallesi  
Şehit Yılmaz Özdemir Caddesi  
Sanayi Sokak No: 4  
Küçükçekmece, İstanbul, Türkiye

**P:** +90.212 698 02 25

**P:** +90.212 698 02 26

**P:** +90.212 565 73 03

[info@activent.com.tr](mailto:info@activent.com.tr)

[www.activent.com.tr](http://www.activent.com.tr)

